

# B44.2

FACTORY  
**Team**

#9062 RC10B44.2 Factory Team Kit

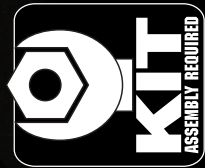

1:10 Scale Electric 4WD Off Road Competition Buggy Kit Manual & Catalog 9/12

# TEAM ASSOCIATED

The logo for BAE, consisting of the letters "BAE" in a stylized, italicized, white font with a black outline, set against a white oval background.

Designed in California, USA

## :: Introduction

Thank you for purchasing this Team Associated product. This assembly manual contains instructions and tips for building and maintaining your new RC10 B44.2. Please take a moment to read through this manual to help familiarize yourself with these steps.

We are continually changing and improving our designs; therefore, actual parts may appear slightly different than in the illustrations. New parts will be noted on supplementary sheets located in the appropriate parts bags. Check each bag for these sheets before you start to build.

## :: KIT Features

The B44 platform has had a long and very successful legacy winning several IFMAR Worlds titles and races all over the world. The B44.2 is the latest in B44 refinement with improved jumping and cornering handling characteristics as well as overall durability. The B44.2 features new 12mm shocks with concentricity building cartridge hat bushings, captured with an aluminum cap for the smoothest and most consistent strokes. The 12mm shocks also feature new Factory Team high precision 12mm springs, which are black-oxide coated to prevent rusting without affecting tolerances. The new battery cradle allows for battery placement adjustment to fine tune weight distribution, and allowing for quick and easy battery changes with the new strap design. The center divider of the battery cradle can be replaced with an optional (not included) ballast weight for more rearward weight bias. Motor installation and adjustment is a breeze thanks to the cam motor mount system. To make the drivetrain more robust the VTS slipper was implemented to provide better adjustment resolution and consistency, while the new 12mm rear clamping hexes aide in putting down the power through the new 12mm hex wheels. The blue aluminum rear hubs add durability and optional camber link adjustment options. Lastly, the B44.2 comes with the latest JConcepts +8mm Finisher body and FT protective chassis sheet.

Features in the B44.2 Factory Team:

- Chassis is lengthened 8mm and narrower by 3mm utilizing 2.5mm carbon fiber chassis for LiPo saddle packs only.
- New molded battery tray allows for forward/ back battery position adjustment with molded battery spacer.
- Updated 3.5 mm front shock tower and 3.0mm rear shock tower with clearance for 12mm shocks and an additional inside shock mount location.
- Updated front arm with reinforcement rib.
- Updated front top deck for more durability and rigidity along with a locking antenna mount.
- Machined 7075-T6 aluminum Cam motor mount set.
- Factory Team 0 degree 7075-T6 aluminum rear hubs with oversize outer bearing.
- FT 12mm anodized shock bodies and threaded collars, with concentric hat bushing cartridge and machined aluminum cap.
- VTS slipper assembly with high-rate spring.
- JConcepts +8mm Finisher body.
- FT protective chassis sheet.
- Rear anti-roll bar included.
- Hard anodized aluminum shock caps with bleed screws.
- TiN "Gold" 3mm shock shafts front and rear.
- Molded pivoting quick change battery straps with locking thumb knobs.
- FT 12mm aluminum rear clamping hexes and 12mm hex rear wheels.

## :: Additional Features

B44.2 F.T. Additional Kit Features:

- Ball differentials with Carbide diff balls and light-weight outdrives
- CVA joints with pin retainer clips
- Factory Team blue aluminum servo mounts
- Factory Team blue aluminum shock pivot balls
- Fully adjustable camber, and toe-in
- Vertical ball end adjustment front & rear
- Dual-sided externally adjustable slipper clutch
- Factory Team blue Titanium turnbuckles
- Factory Team blue aluminum shock bushings
- Ball-bearings steering bell cranks
- Built in servo saver

## :: Other Helpful Items

- Silicone Shock Fluid (Refer to catalog for complete listings)
- Body Scissors (AE Part # 1737)
- FT Hex Wrenches (AE Part # 1655)
- Soldering Iron
- Reamer / Hole Punch
- Needle Nose Pliers
- Calipers or a Precision Ruler
- Wire Cutters
- Multi Tool (AE Part #7494)
- Green Slime shock lube (AE Part # 1105)
- Hobby Knife

**Associated Electrics, Inc.**  
26021 Commercentre Dr.  
Lake Forest, CA 92630



**Customer Service**  
Tel: 949.544.7500  
Fax: 949.544.7501

**:: Table of Contents**

1.....Cover	15.....Rear CVA Build
2.....Introduction	15 - 16.....Rear Suspension Build
3.....Table of Contents	16.....Rear Anti-Roll Bar Build
4.....Front / Rear Differential Build	17.....Battery Tray Build
5.....Front Gearbox Build	18 - 19.....Shock Build
6.....Rear Gearbox Build	19 - 20.....Servo Build
7 - 8.....Steering and Center Battery Brace Build / Install	20.....Electronics Install
8 - 9.....Front End Build	21 - 22.....Body, Wheel, Tires Install
9.....Rear End Build	22.....Servo Chart
10.....Slipper Build	23 - 24.....Tuning Tips
11.....Center Bulkhead Mounts	25-33.....Catalog
11.....Front Top Deck Build	34.....Notes
12.....Rear Top Deck Build	35.....Setup Sheet "Kit Setup"
13.....Turnbuckles Build	36.....1:1 Hardware "Fold Out"
13.....Front CVA Build	37.....Setup Sheet "Blank"
13-14.....Front Suspension Build	38.....Back Cover

**:: Notes**

This symbol indicates a special note or instruction in the manual.



**There is a 1:1 hardware foldout page in the back of the manual. To check the size of a part, line up your hardware with the correct drawing until you find the exact size. Each part in the foldout has a number assigned to it for ordering replacement parts.**

**Associated Electrics, Inc.**  
26021 Commercentre Dr.  
Lake Forest, CA 92630



**Customer Service**  
Tel: 949.544.7500  
Fax: 949.544.7501

<http://www.TeamAssociated.com> • <http://www.RC10.com> • [http://twitter.com/Team\\_Associated](http://twitter.com/Team_Associated) • <http://bit.ly/AEonFacebook>

**:: Front and Rear Differential Build - Step 1**

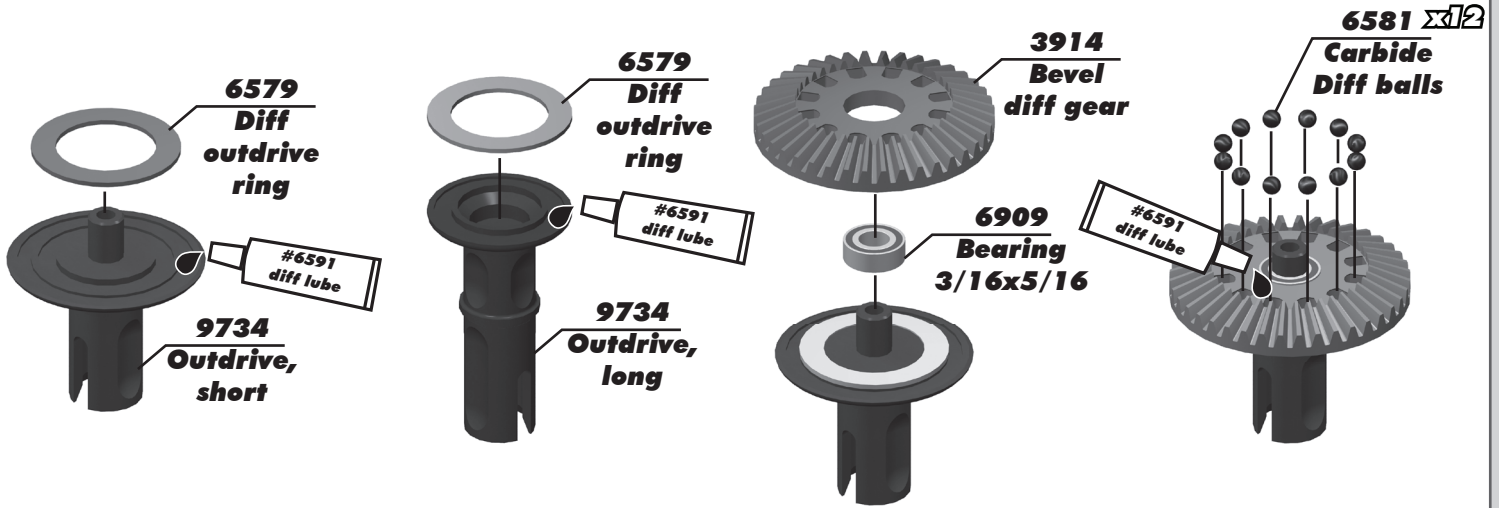

**:: Front and Rear Differential Build - Step 2**

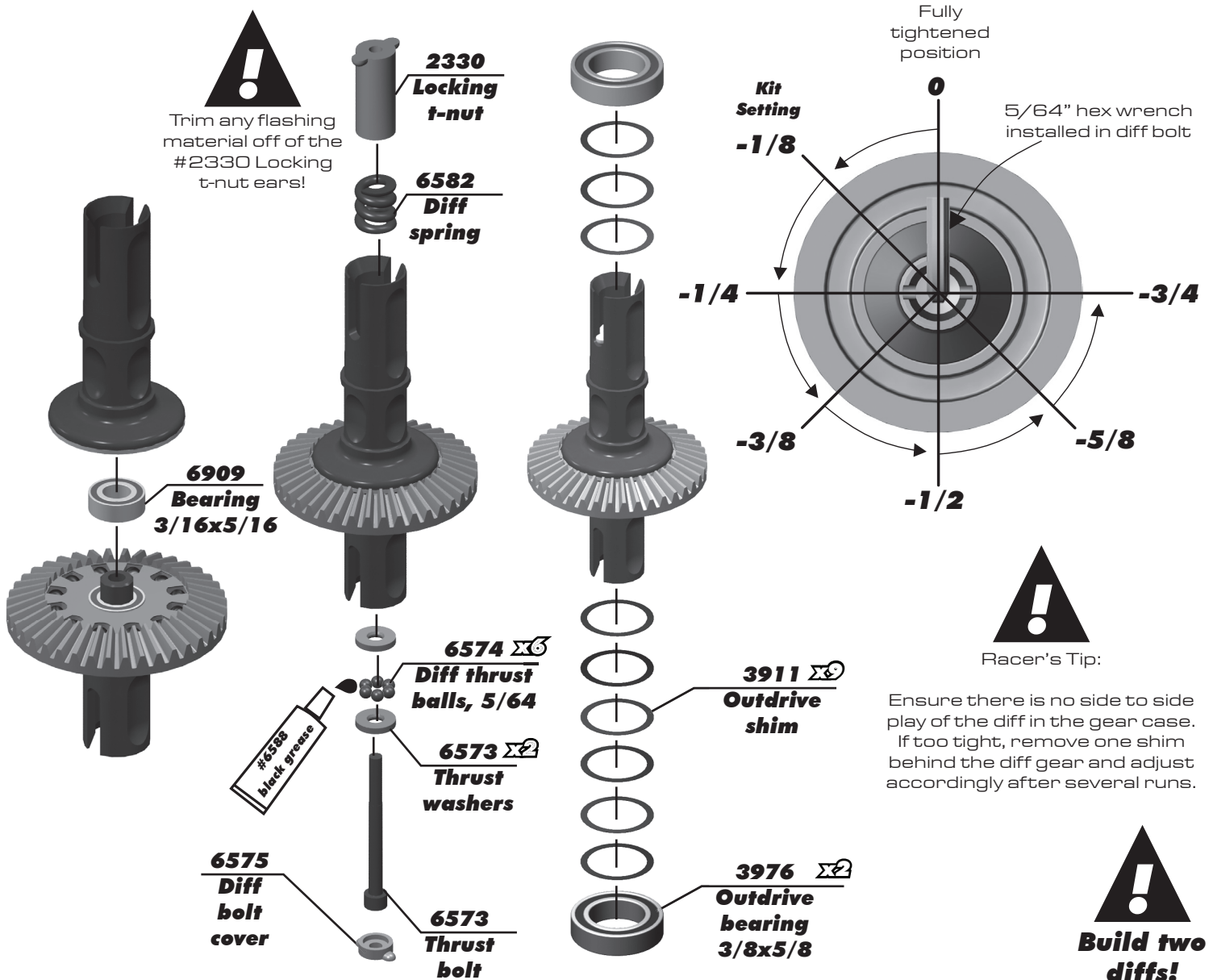

**:: Front Gearbox Build - Step 1**

**7381 CVA coupler**

**#6588 black grease**

**9747 CVA bone center, front**

**9761 CVA input shaft**

**7996 CVA pin retainer**

**7381 CVA pin**

**! Align the gap in the pin retainer to be opposite of the CVA pin.**

**#1597 ca glue**  
**1 drop!**

**Racer's Tip:**  
Try using only 1 drop of CA glue to secure the pin retainer!

**:: Front Gearbox Build - Step 2**

**3977 3/16x3/8 bearing**

**3911 Drivetrain shim**

**3903 Drive pinion**

**3919 Input shaft pin**

**6299 E-clip, 1/8**

**! Trim flashing off back of gear. Align the slot in the pinion gear with the pin!**

**:: Front Gearbox Build - Step 3**

**#6591 diff lube**  
**1 drop!**

**9733 Lower transmission case**

**9733 Upper transmission case**

**6860 FT 4-40x3/8 shcs aluminum, blue**

**#6591 diff lube**  
**1 drop!**

**:: Rear Gearbox Build - Step 1**

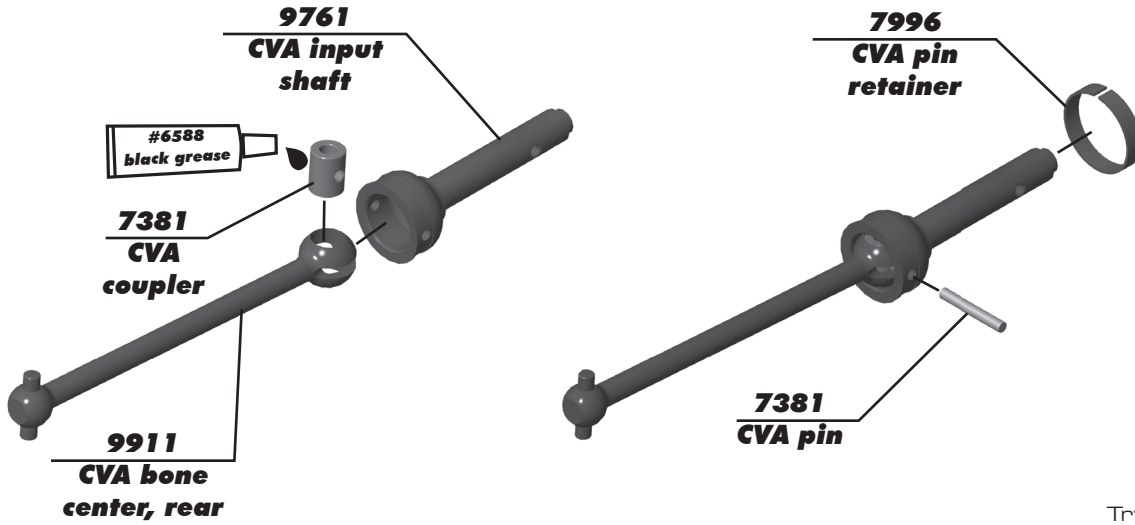

**!**  
Align the gap in the pin retainer to be opposite of the CVA pin.



Racer's Tip:  
Try using only 1 drop of CA glue to secure the pin retainer!

**:: Rear Gearbox Build - Step 2**

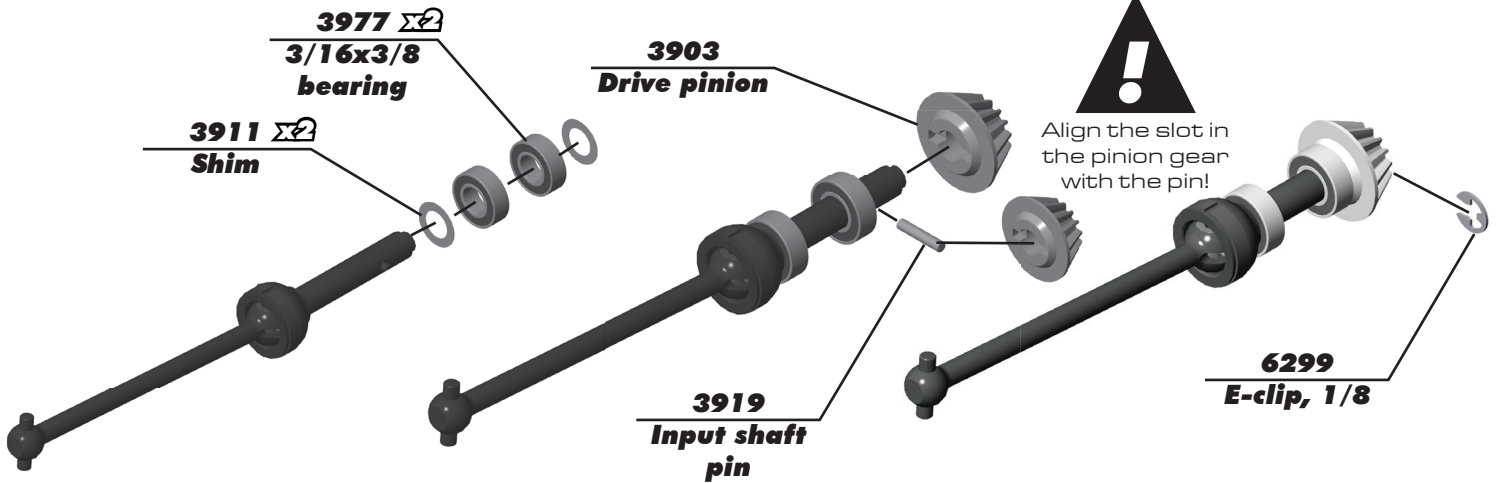

**!**  
Align the slot in the pinion gear with the pin!

**:: Rear Gearbox Build - Step 3**

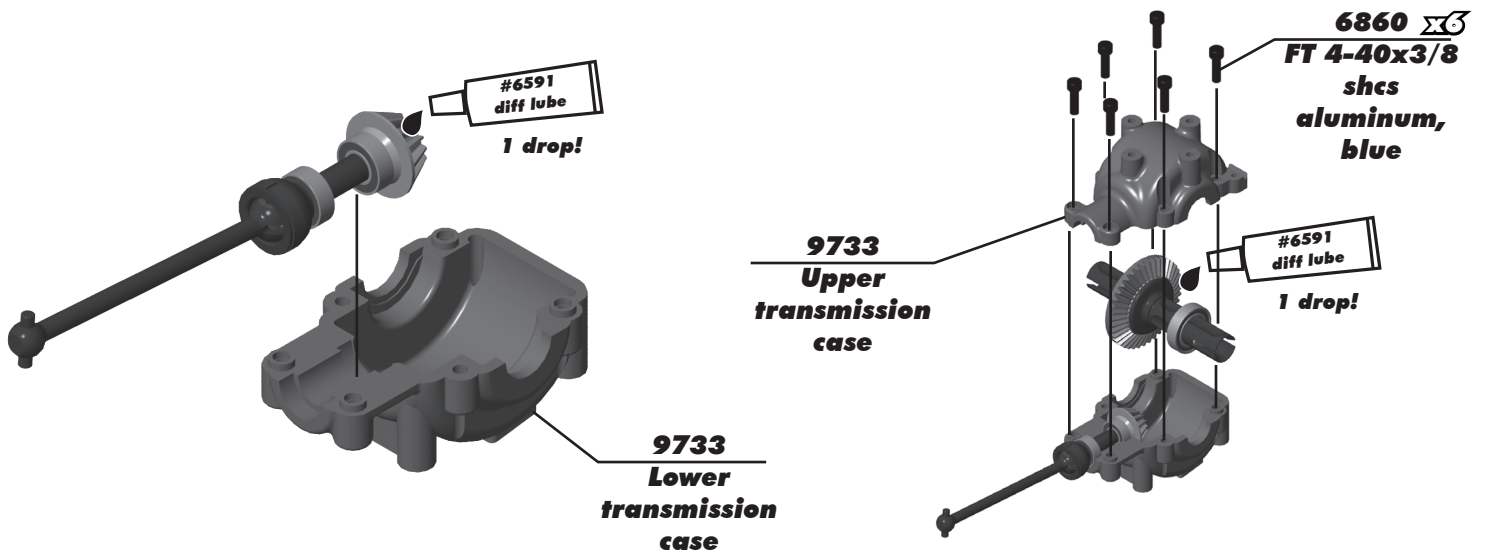

**6860**  $\Sigma 6$   
**FT 4-40x3/8**  
shcs  
aluminum,  
blue

**9733**  
**Upper**  
**transmission**  
**case**

**9733**  
**Lower**  
**transmission**  
**case**

**#6591**  
**diff lube**  
**1 drop!**

**:: Steering and Center Battery Brace Build Step 1**

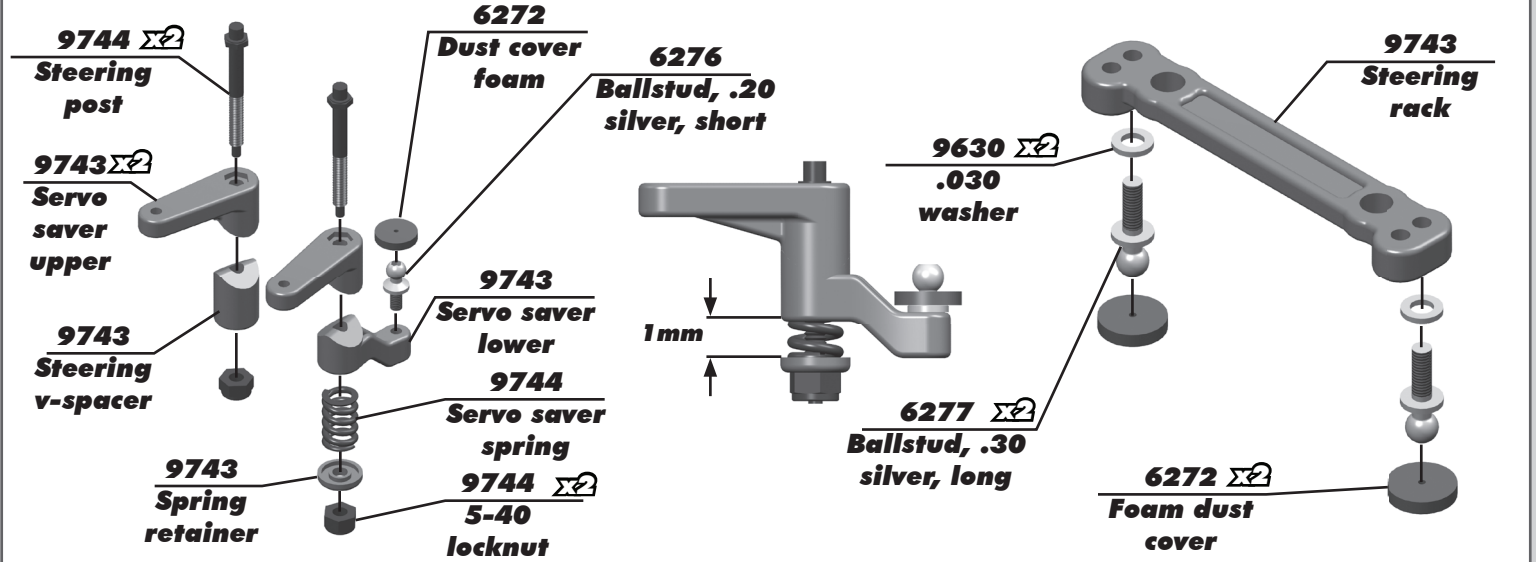

**:: Steering and Center Battery Brace Build Step 2**

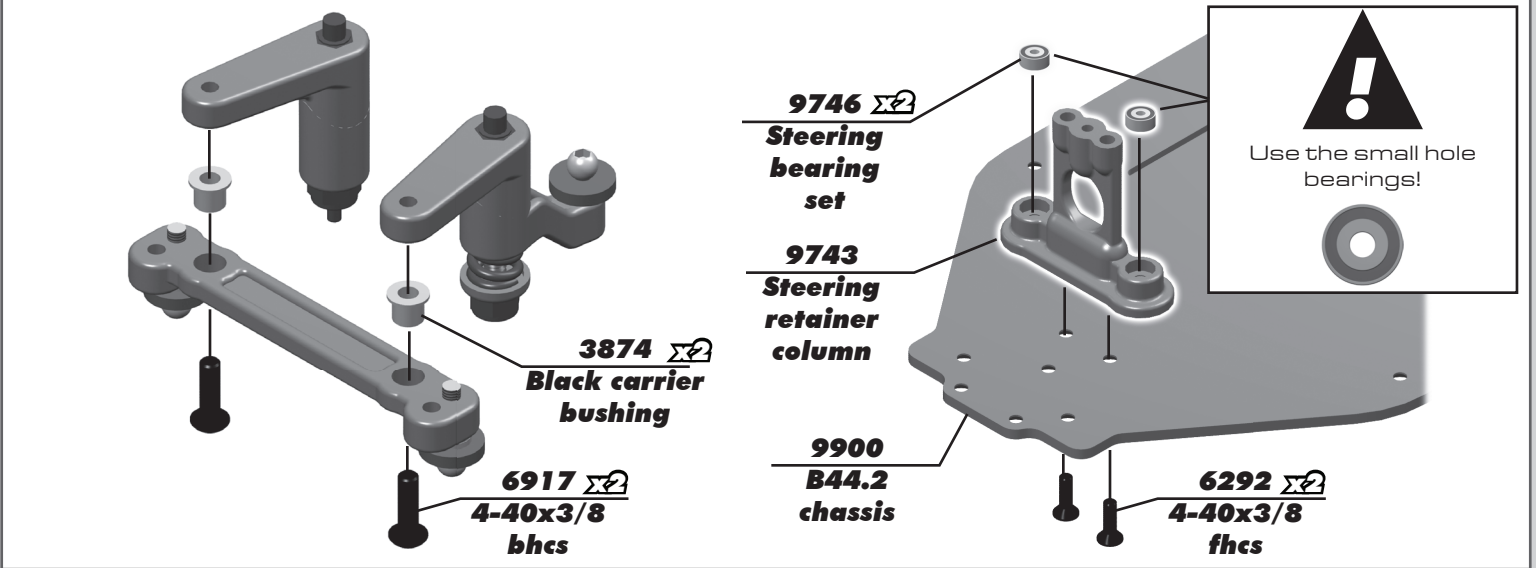

**:: Steering and Center Battery Brace Build Step 3**

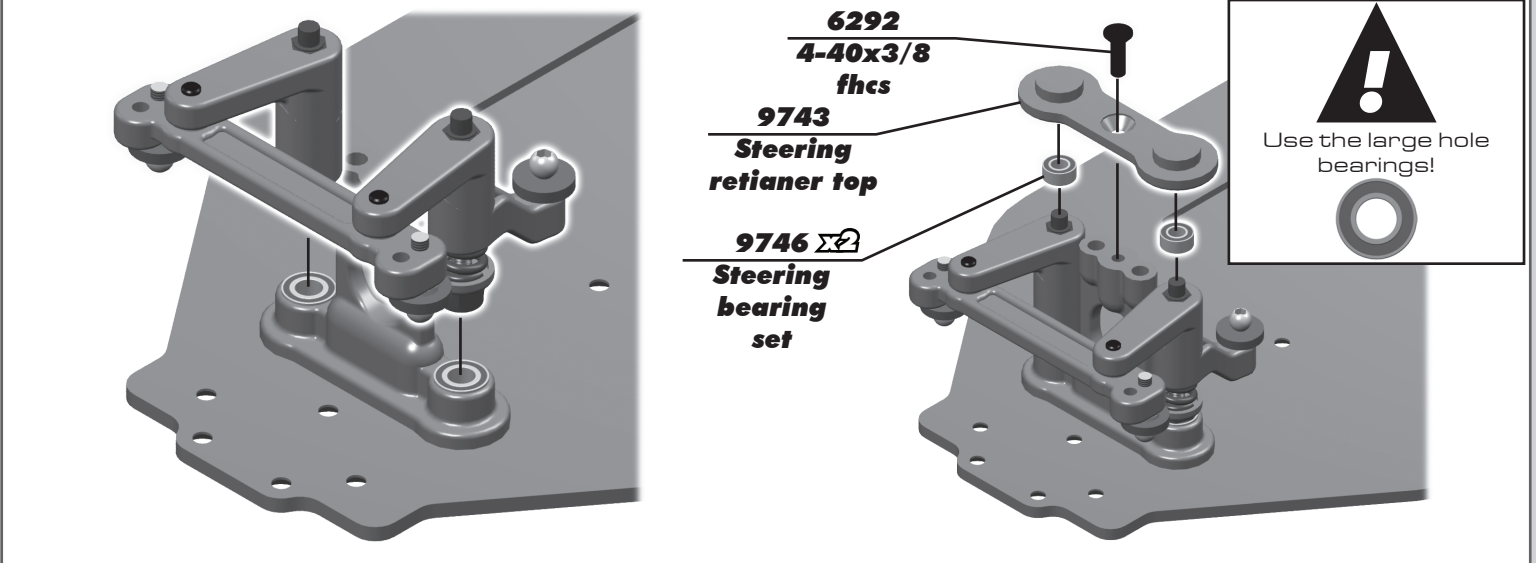

**:: Steering and Center Battery Brace Build / Install Step 4**

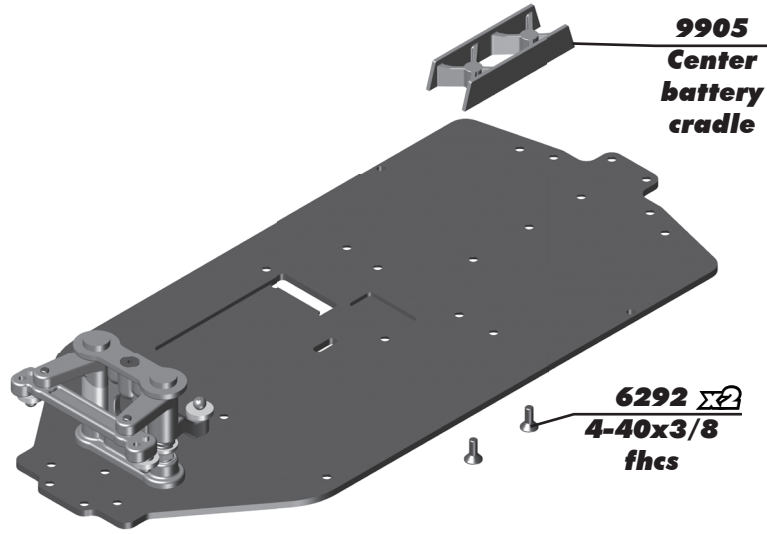

**:: Front End Build - Step 1**

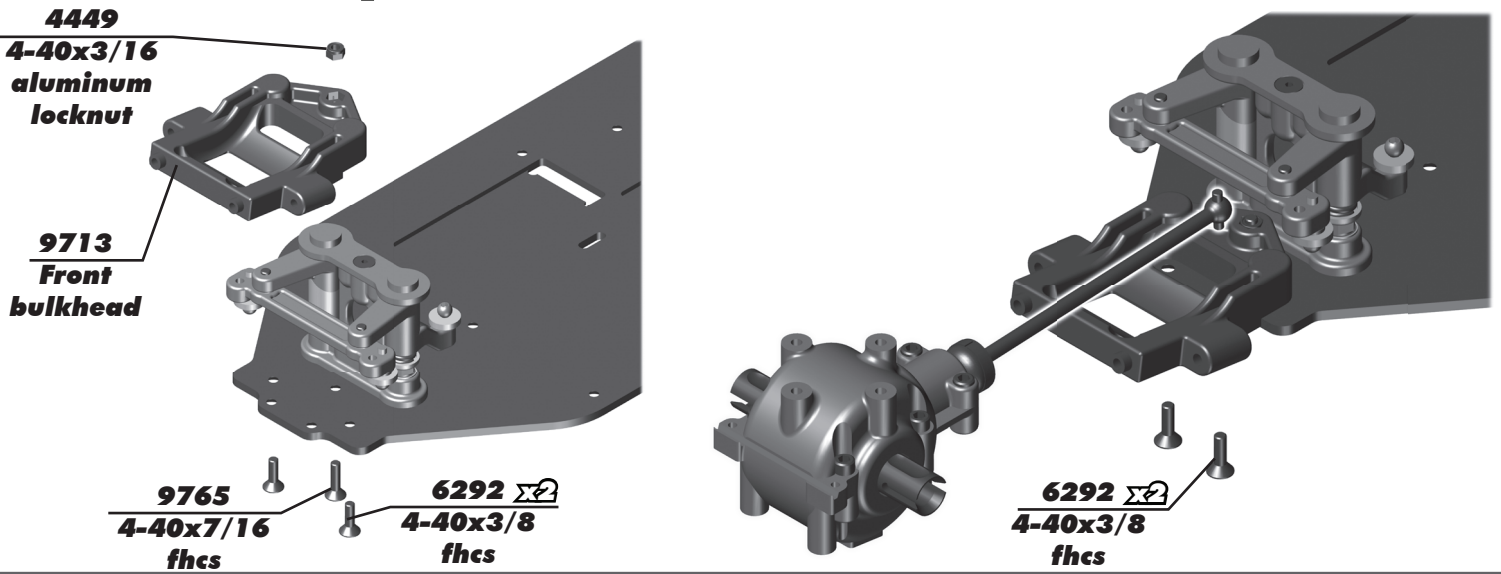

**:: Front End Build - Step 2**

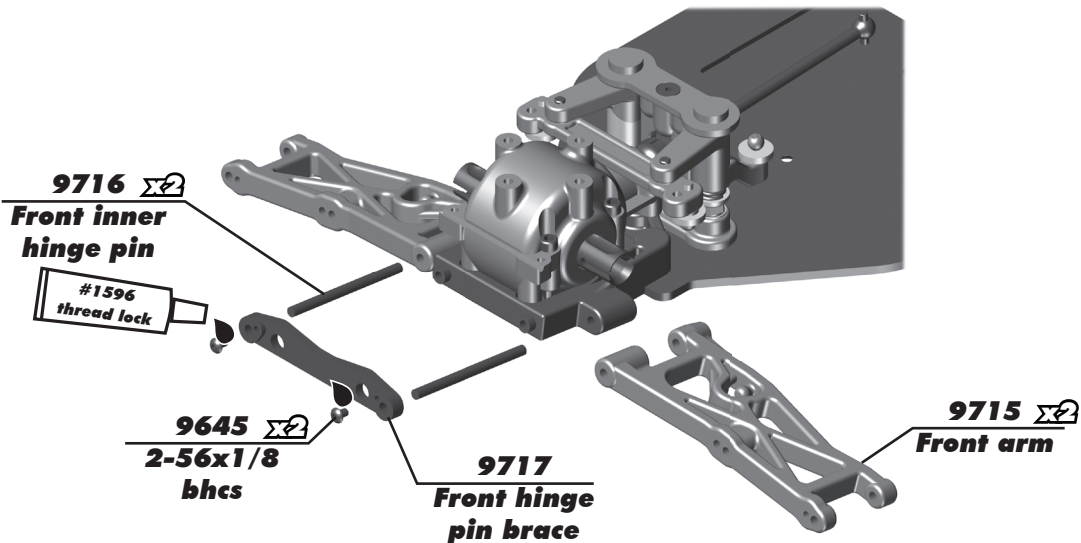

**:: Front End Build - Step 3**

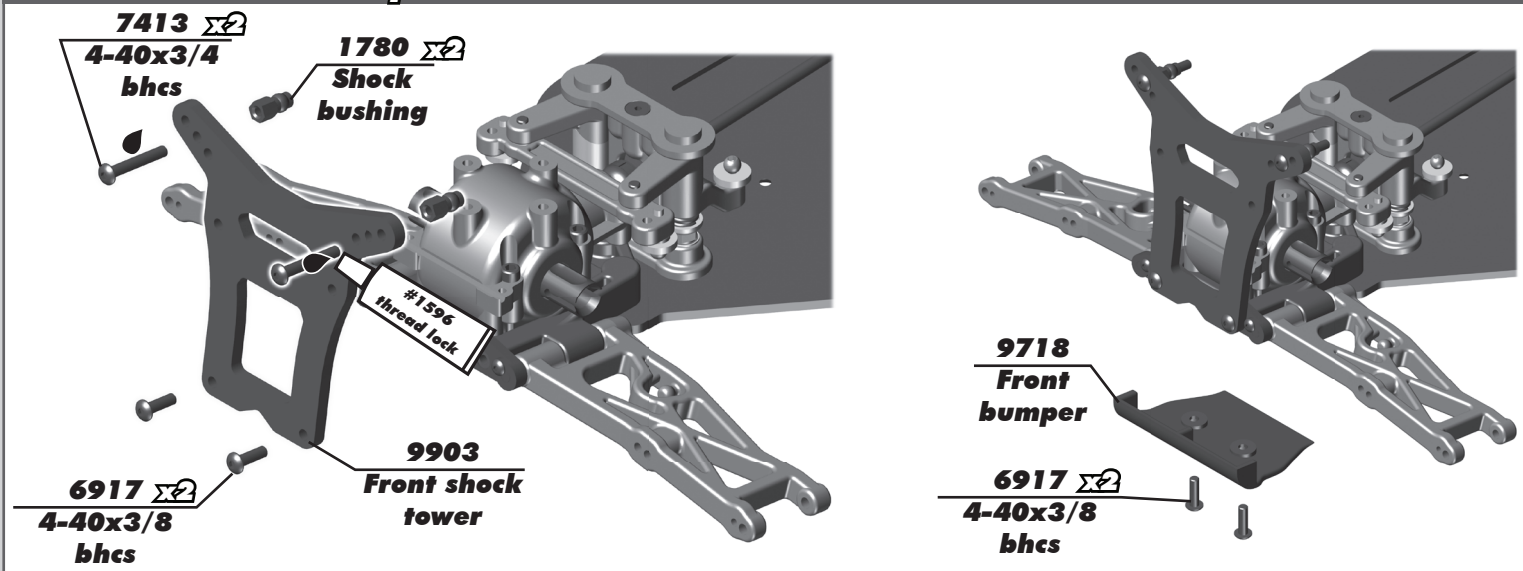

**:: Rear End Build - Step 1**

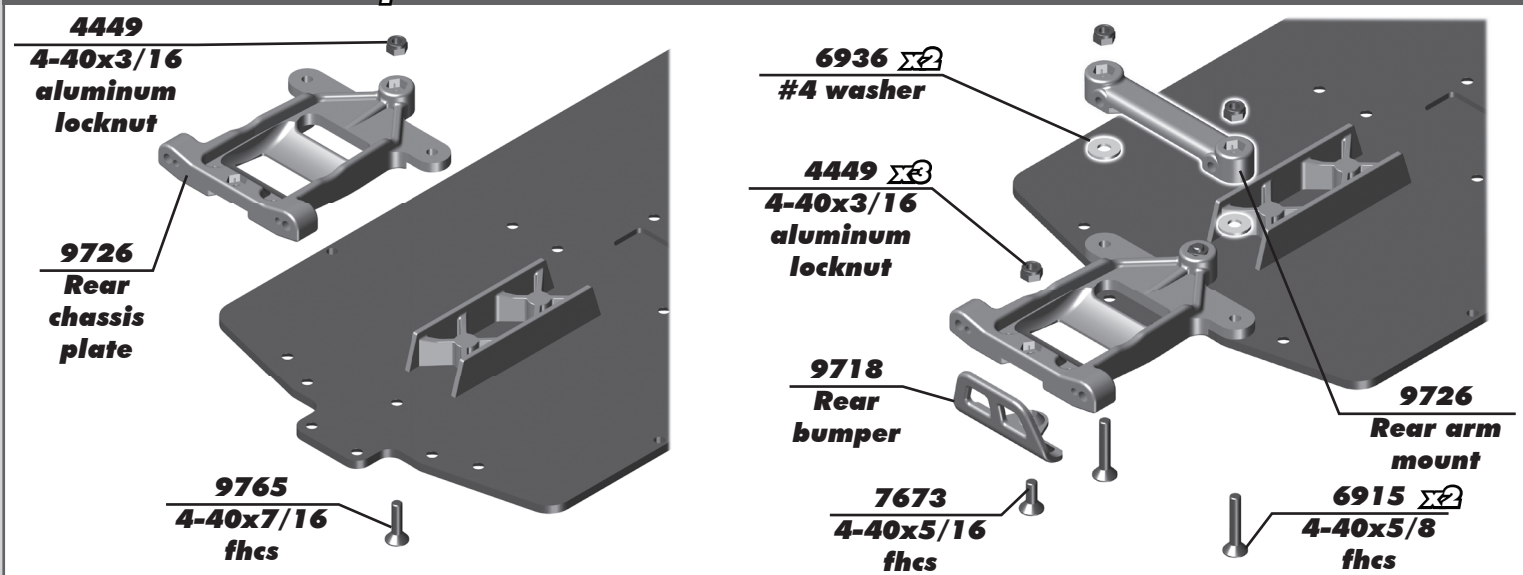

**:: Rear End Build - Step 2**

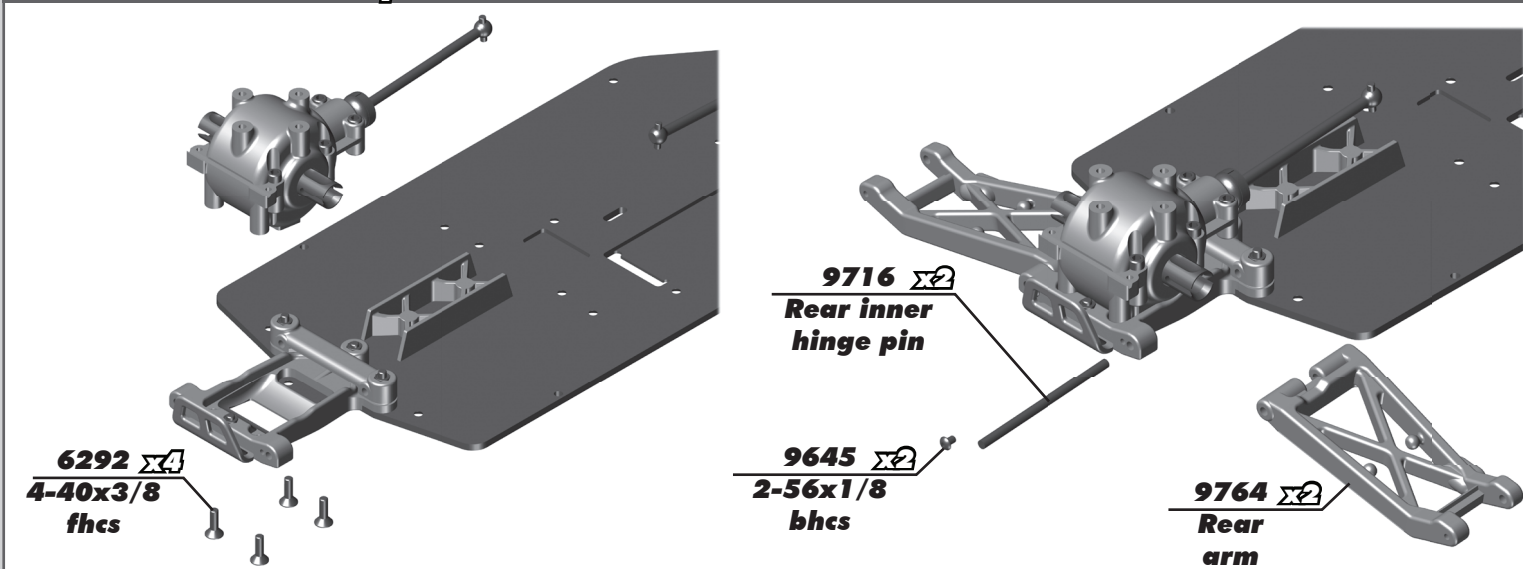

**:: Slipper Build - Step 1**

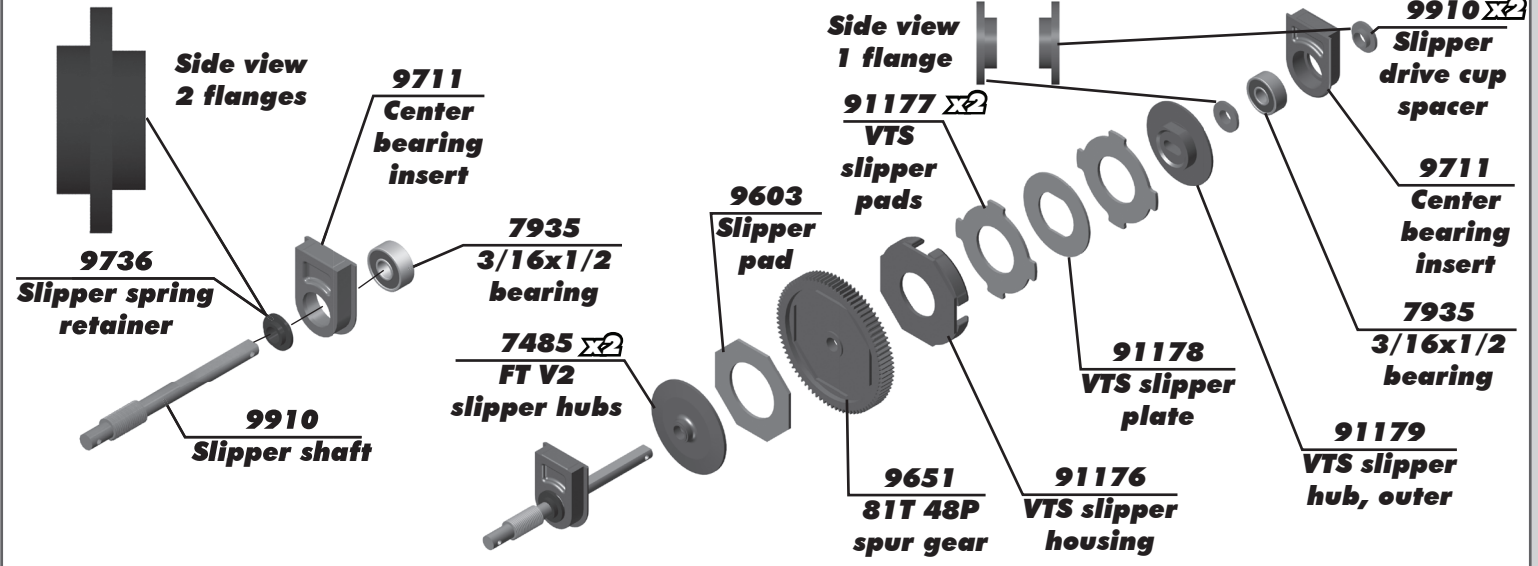

**:: Slipper Build - Step 2**

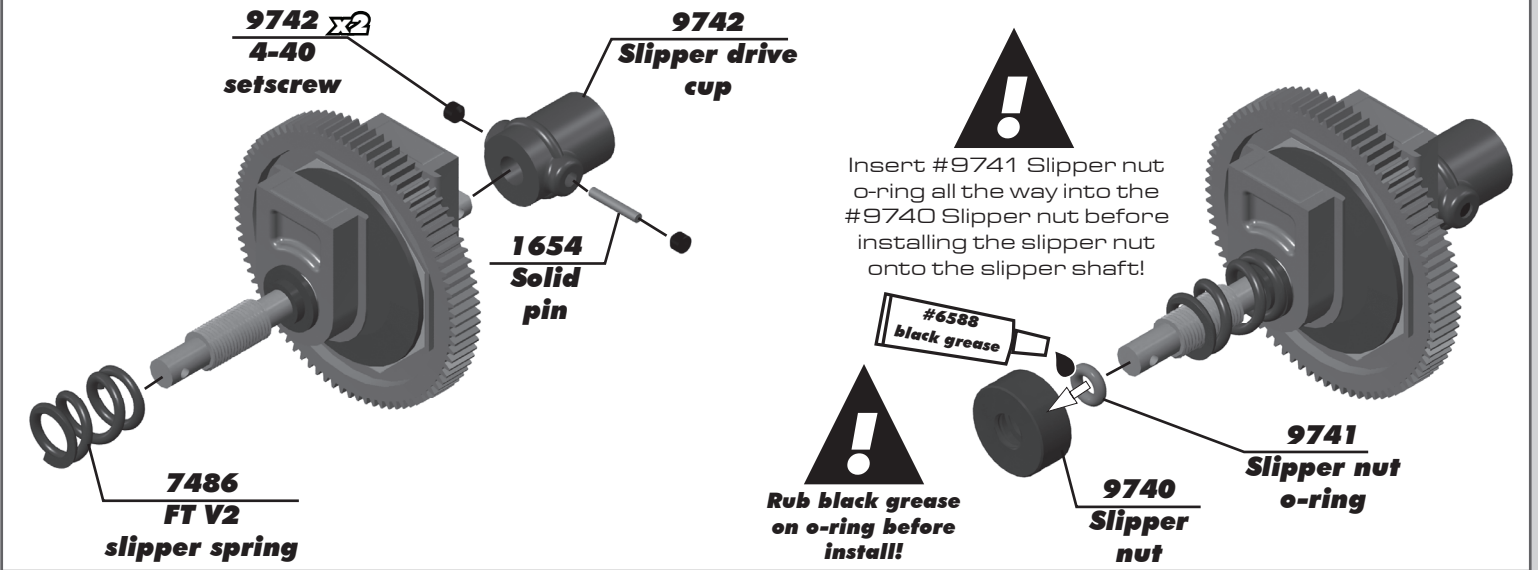

**:: Slipper Build - Step 3**

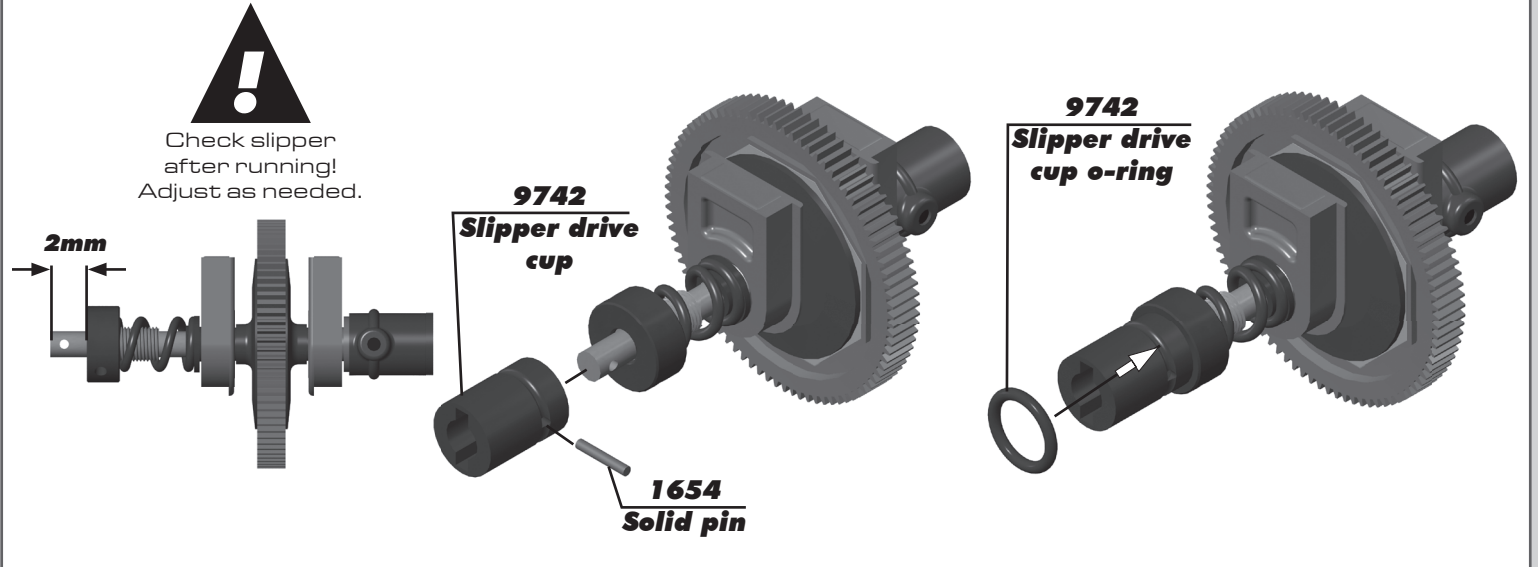

**:: Center Bulkhead Mounts - Step 1**

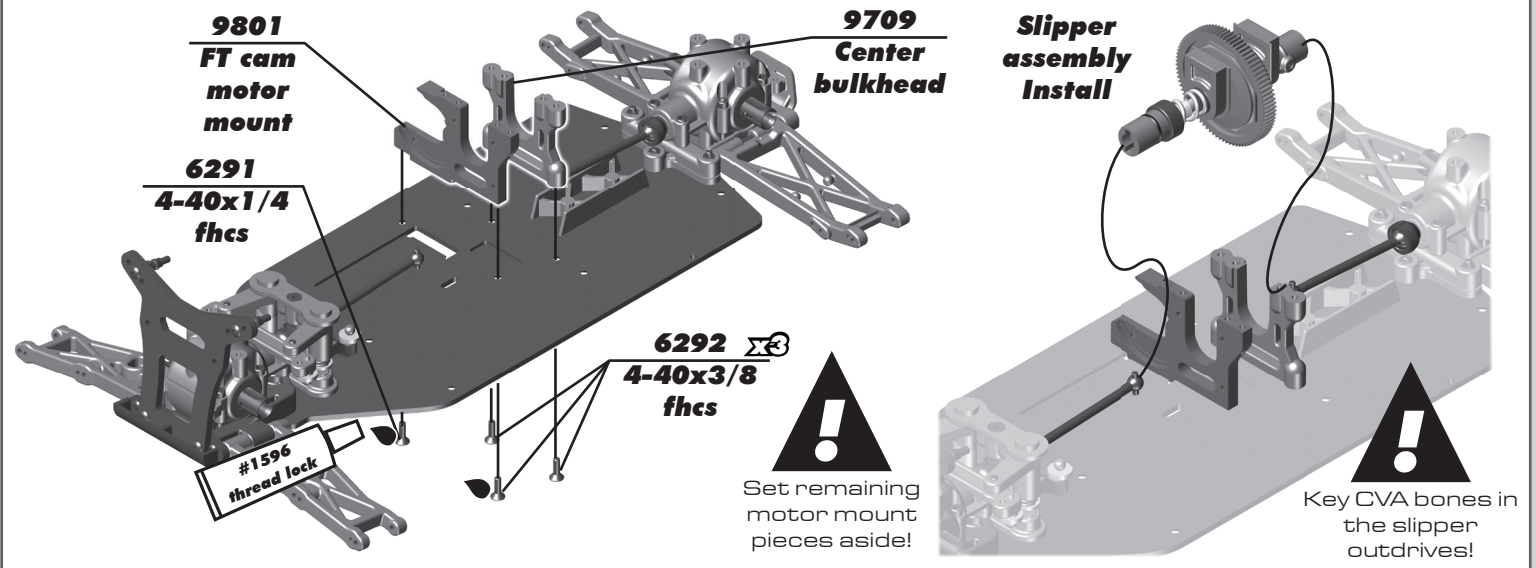

**:: Front Top Deck Build - Step 1**

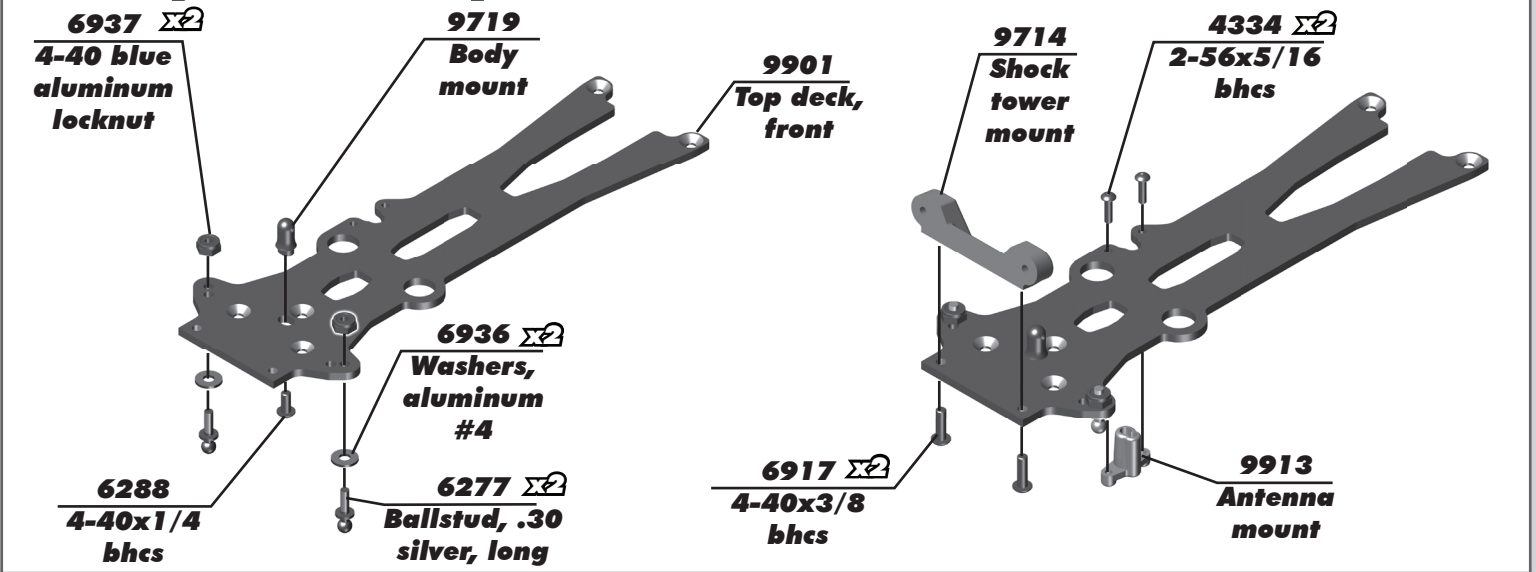

**:: Front Top Deck Build - Step 2**

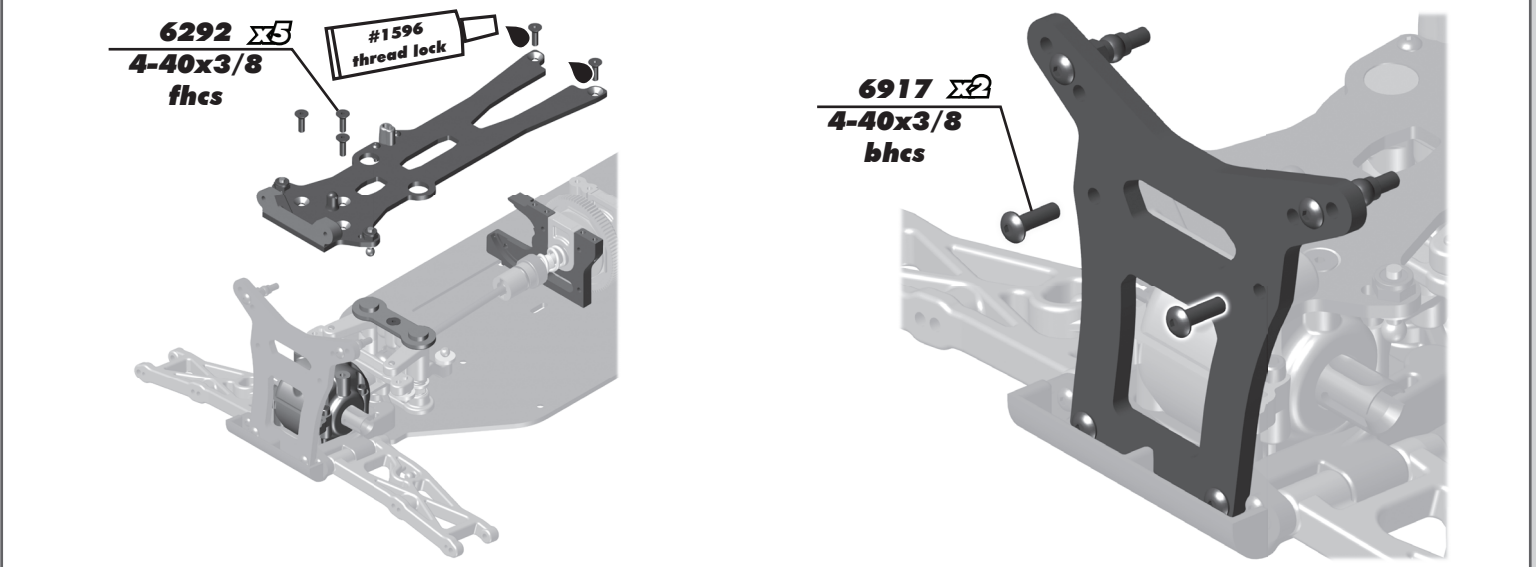

**:: Rear Top Deck Build - Step 1**

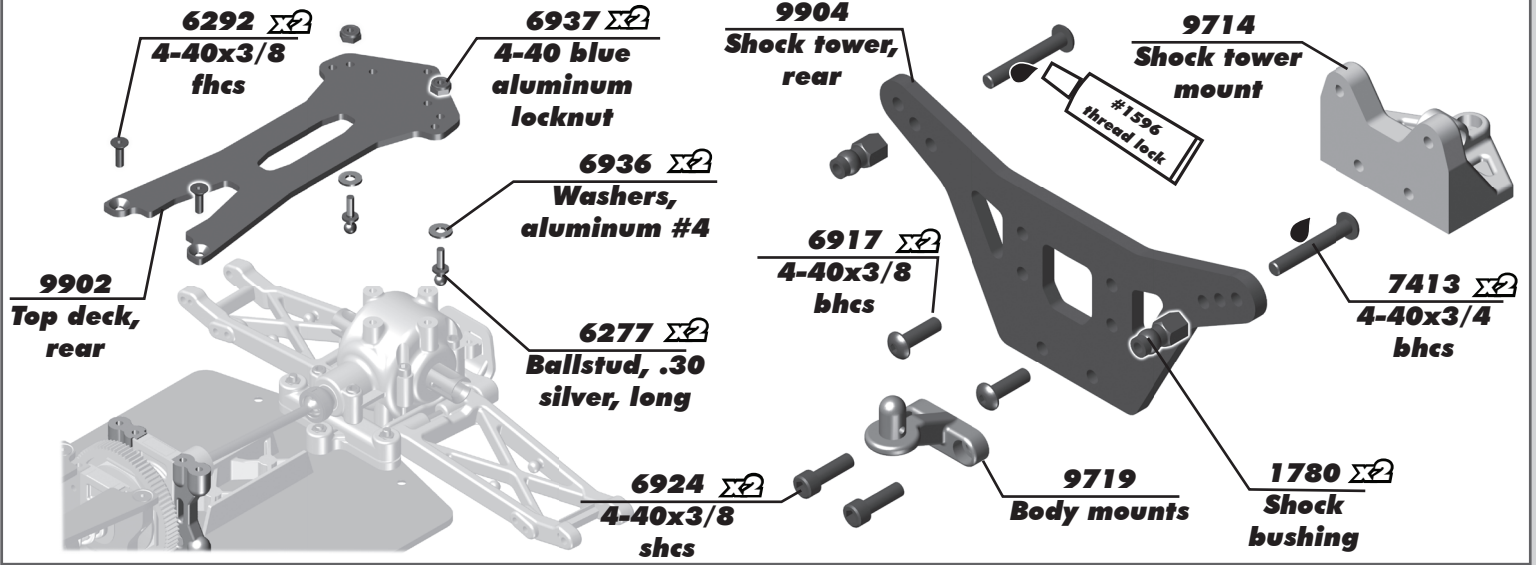



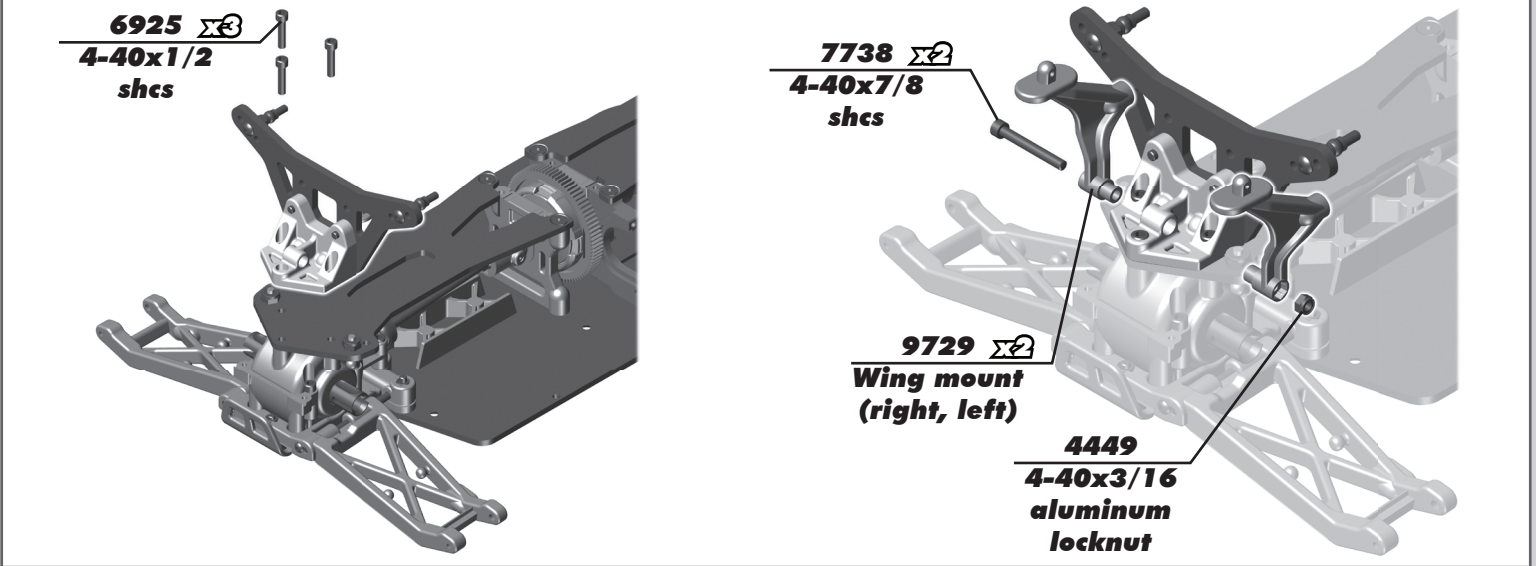



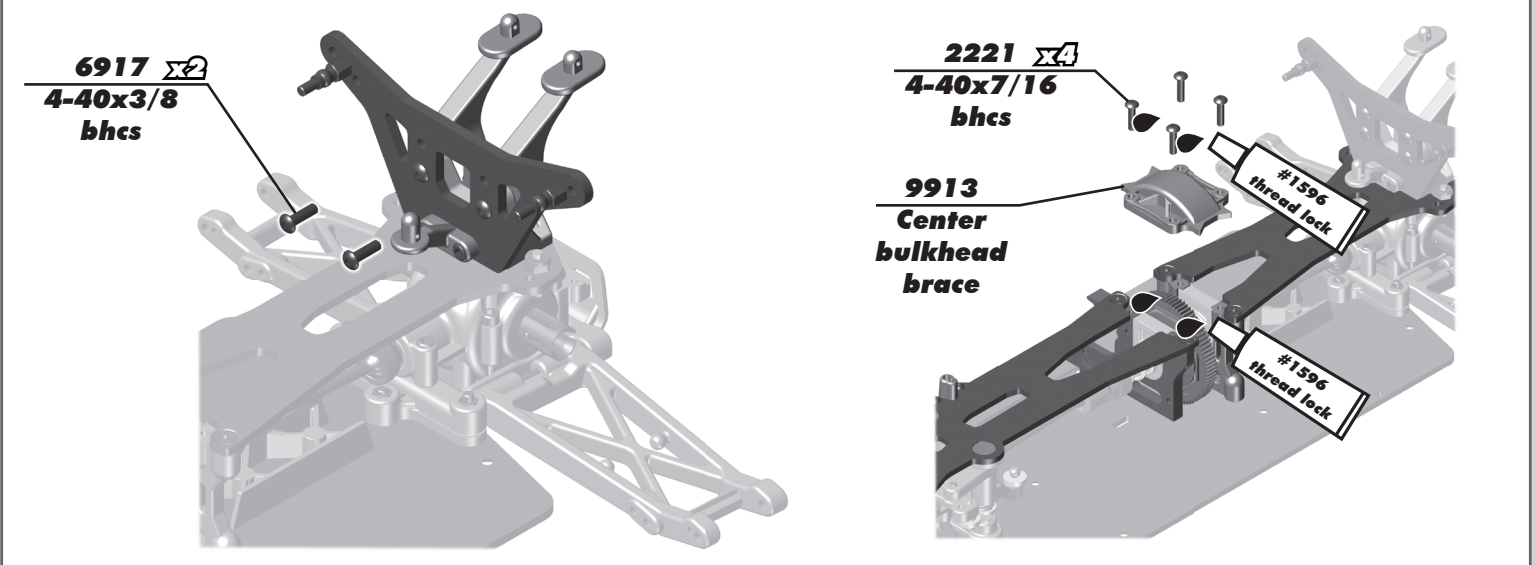

**:: Rear Top Deck Build - Step 2**



**:: Rear Top Deck Build - Step 3**



**:: Turnbuckles Build - Step 1**

<p><b>Front Steering Link</b></p>  <p><b>1404</b> FT titanium turnbuckles 1.77</p>	<p><b>7230</b>  <b>x2</b> Ball cups, large</p>  <p><b>60mm</b></p> <p><b>Steering Build x2</b></p>
<p><b>Front Camber Link</b></p>  <p><b>1406</b> FT titanium turnbuckles 2.00</p>	<p><b>7230</b>  <b>x2</b> Ball cups, large</p>  <p><b>64.5mm</b></p> <p><b>Front Camber Build x2</b></p>
<p><b>Rear Camber Link</b></p>  <p><b>1406</b> FT titanium turnbuckles 2.00</p>	<p><b>7230</b>  <b>x2</b> Ball cups, large</p>  <p><b>67mm</b></p> <p><b>Rear Camber Build x2</b></p>

**:: Front CVA Build - Step 1**

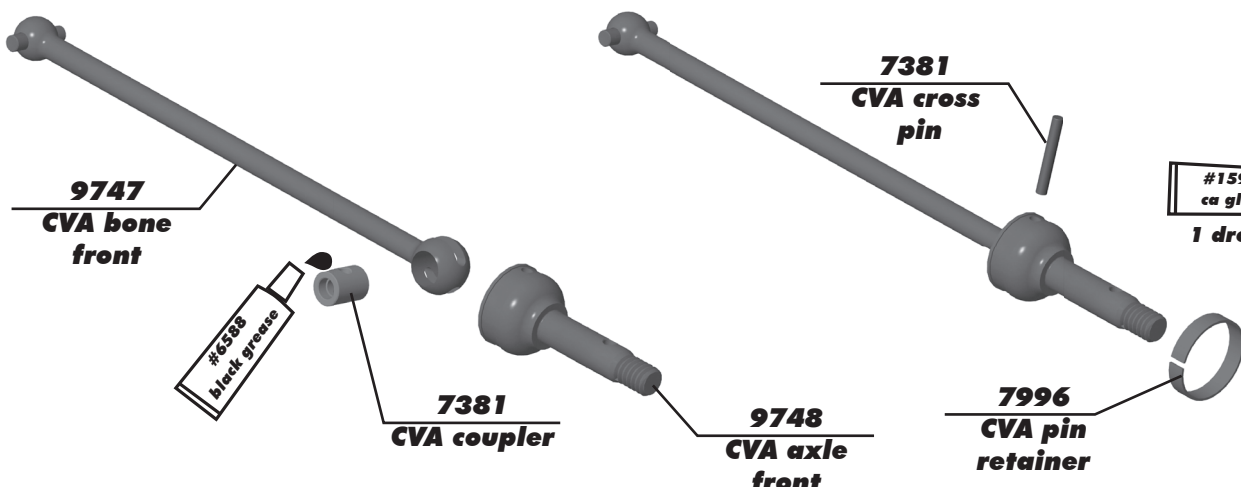

**9747**  
CVA bone  
front

**#6588**  
black grease

**7381**  
CVA coupler

**9748**  
CVA axle  
front

**7381**  
CVA cross  
pin

**7996**  
CVA pin  
retainer

**#1597**  
ca glue  
1 drop!

**Build x2**

Align the gap in the pin retainer to be opposite of the CVA pin.

**:: Front Suspension Build - Step 1**

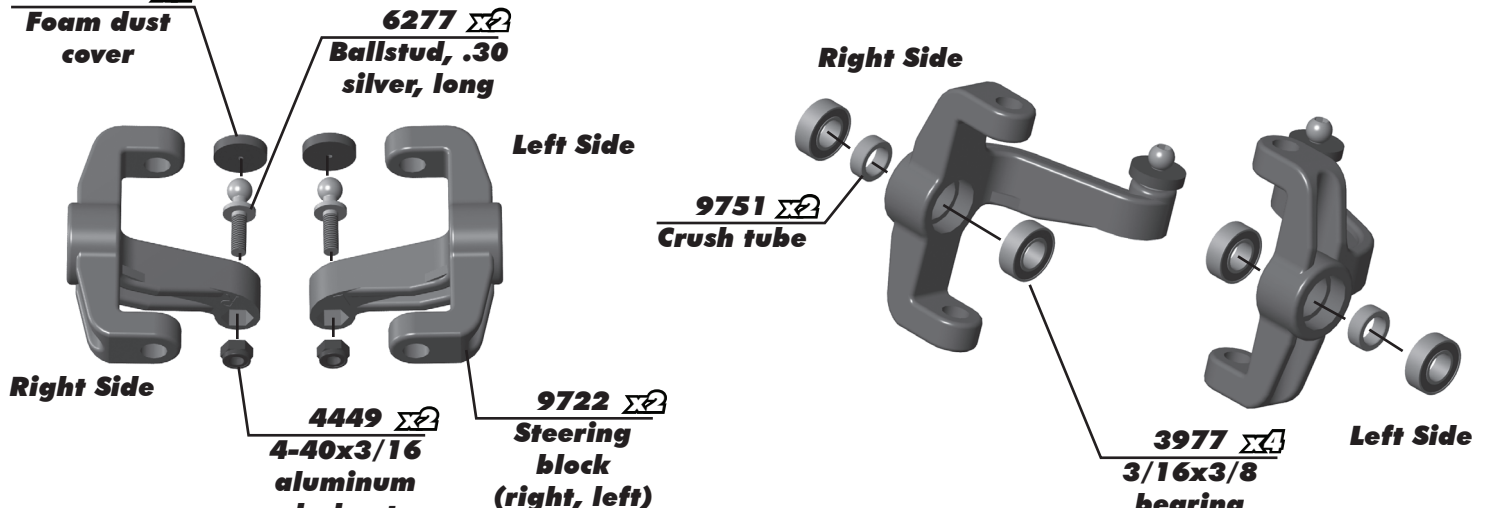



**6272**  **x2**  
Foam dust  
cover

**6277**  **x2**  
Ballstud, .30  
silver, long

**4449**  **x2**  
4-40x3/16  
aluminum  
locknut

**9722**  **x2**  
Steering  
block  
(right, left)

**9751**  **x2**  
Crush tube

**3977**  **x4**  
3/16x3/8  
bearing

**Right Side**

**Left Side**

**:: Front Suspension Build - Step 2**

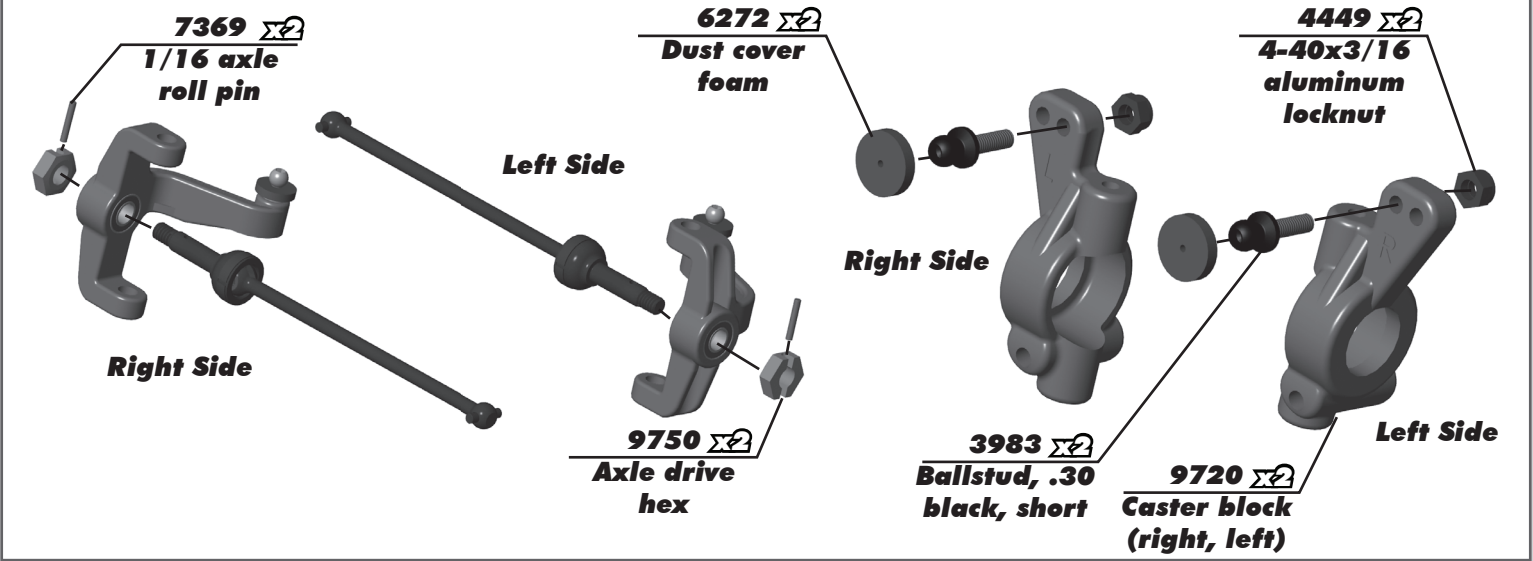

**:: Front Suspension Build - Step 3**

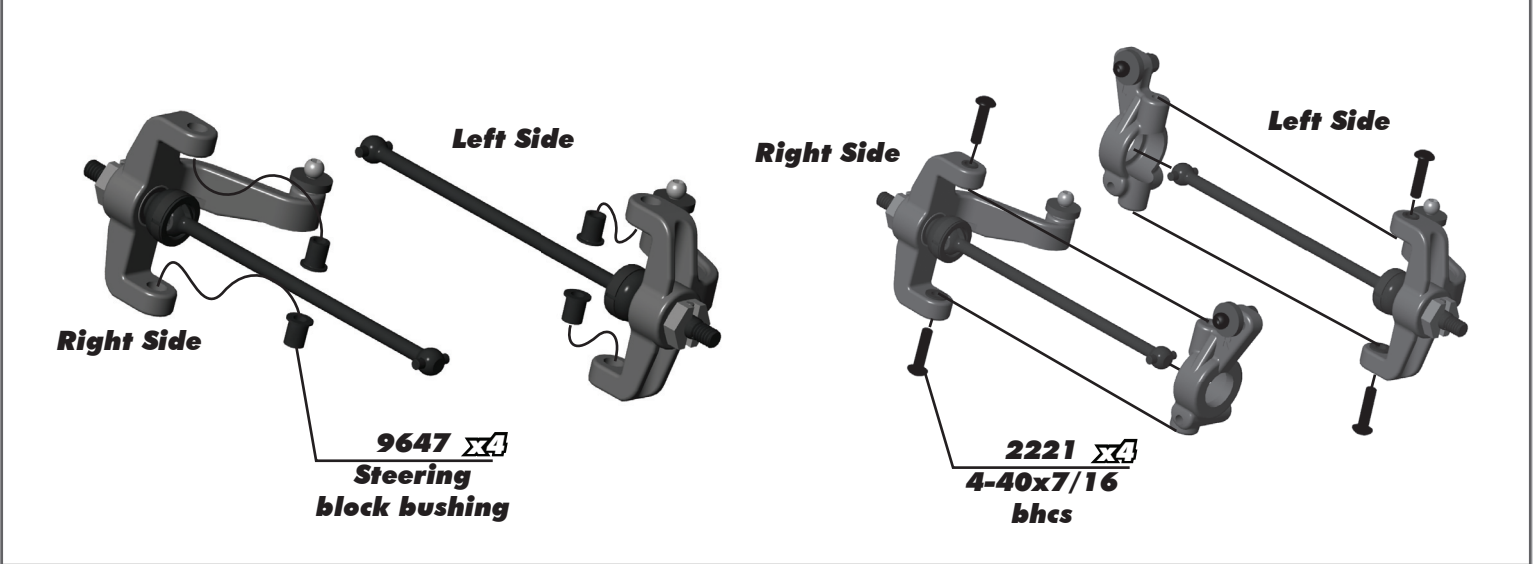

**:: Front Suspension Build - Step 4**

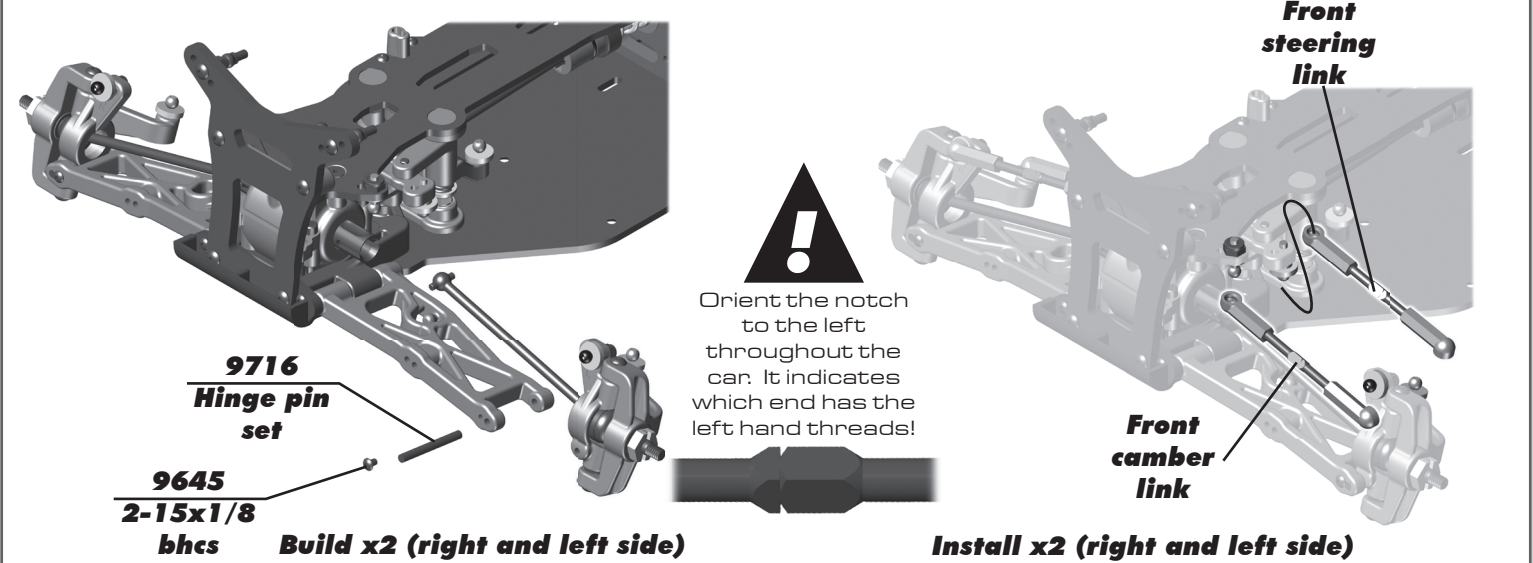

**:: Rear CVA Build - Step 1**

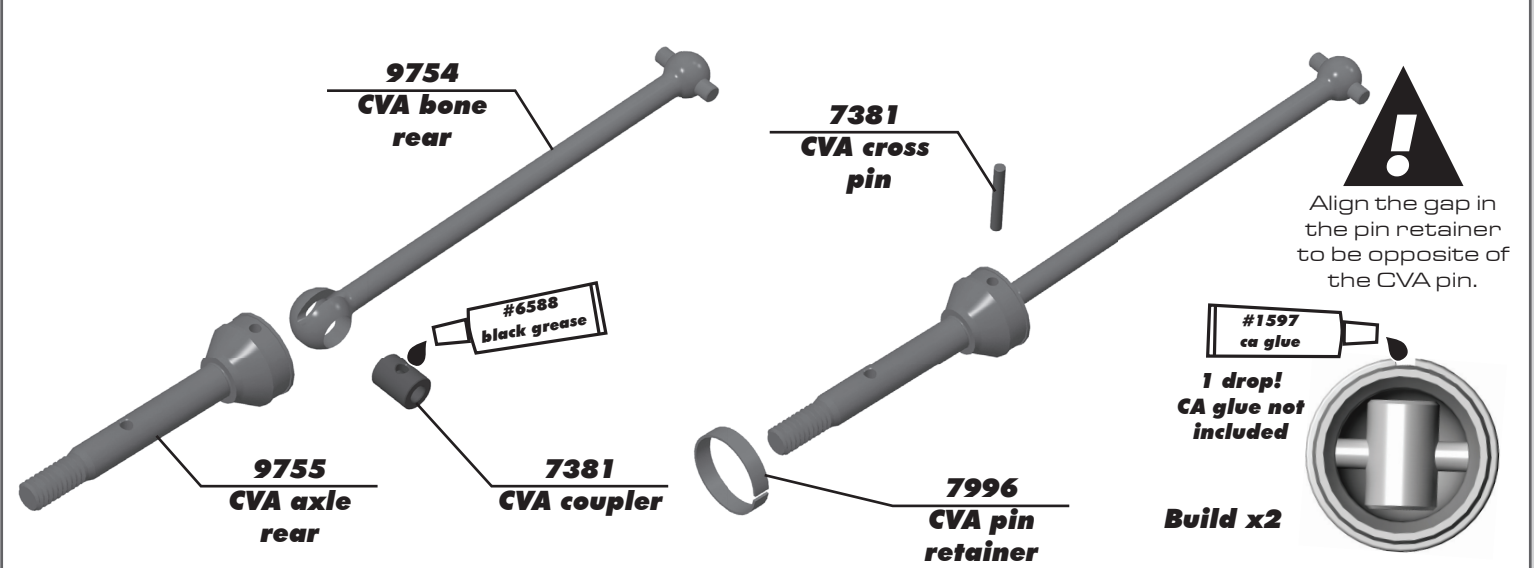

**:: Rear Suspension Build - Step 1**

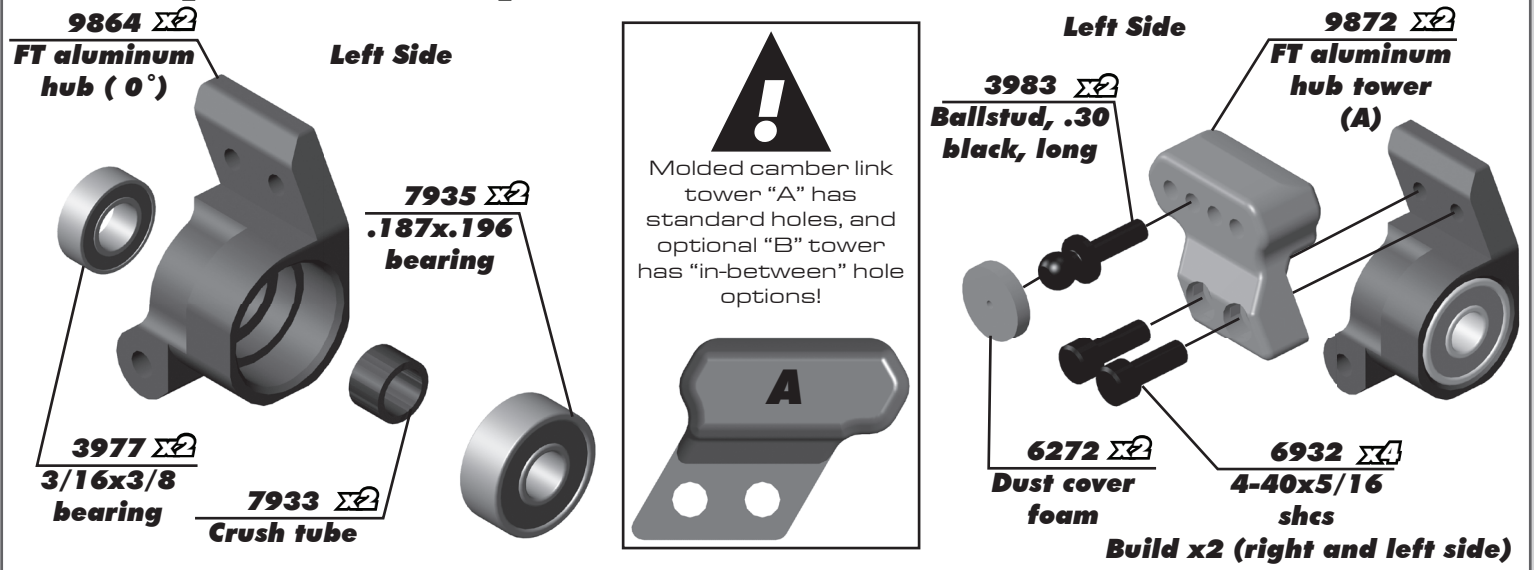

**:: Rear Suspension Build - Step 2**

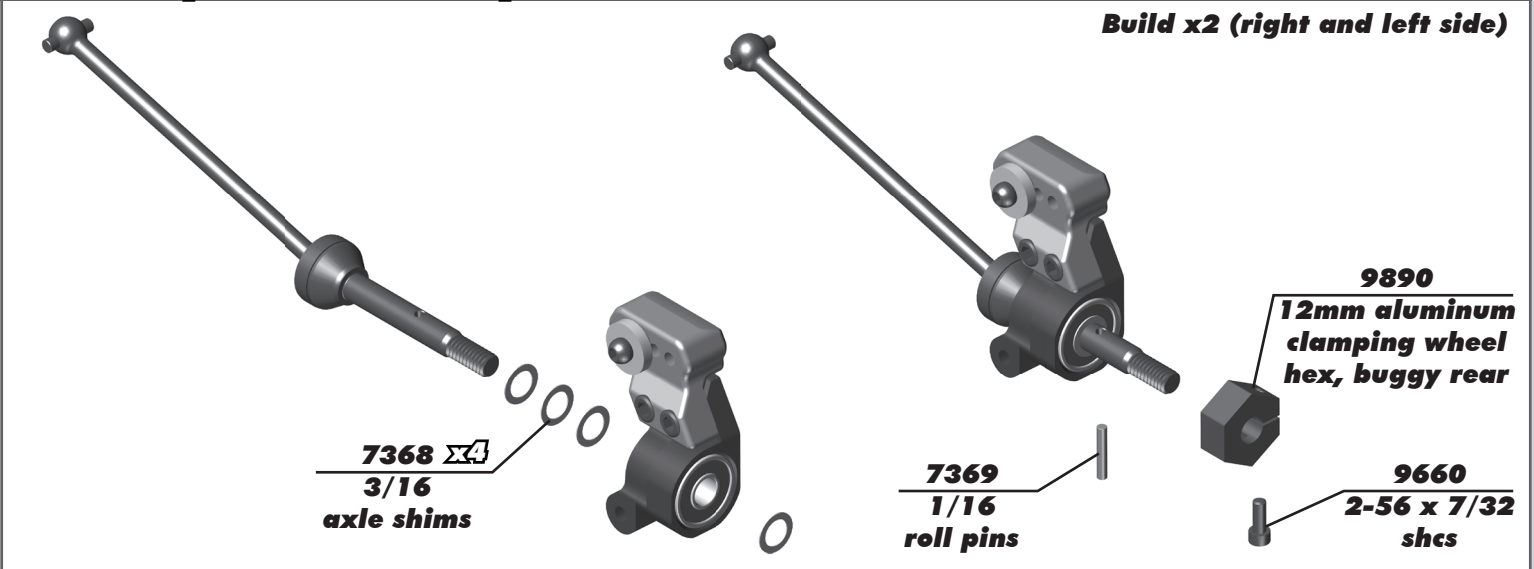

**:: Rear Suspension Build - Step 3**

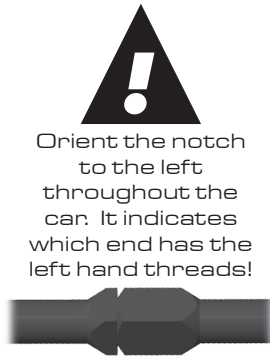
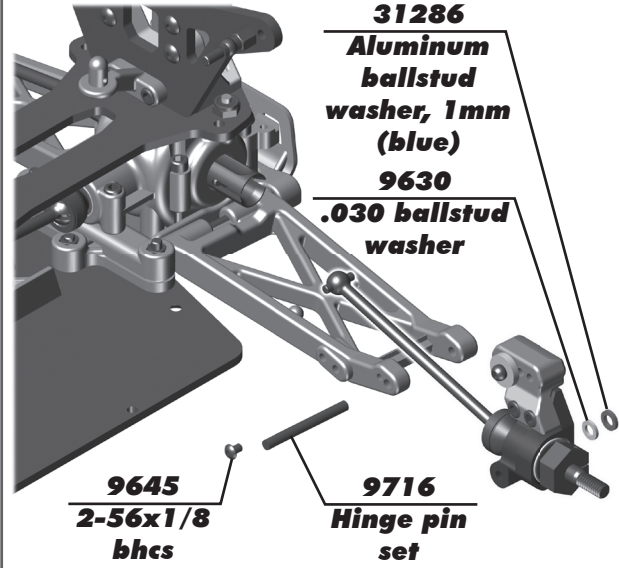

**Install x2 (right and left side)**

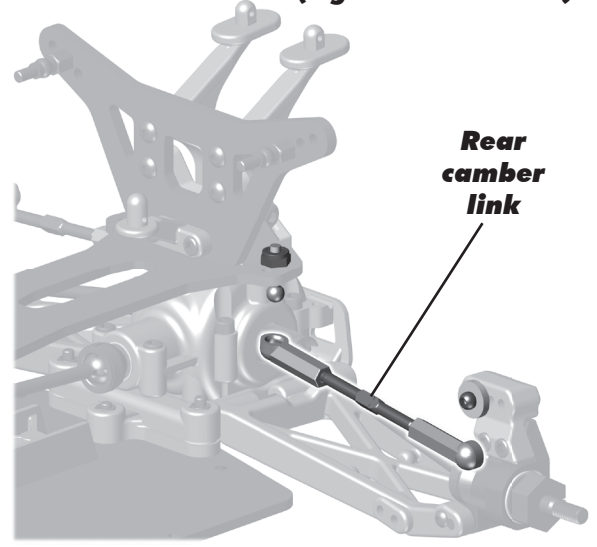

**:: Rear Anti Roll Bar Build - Step 1**

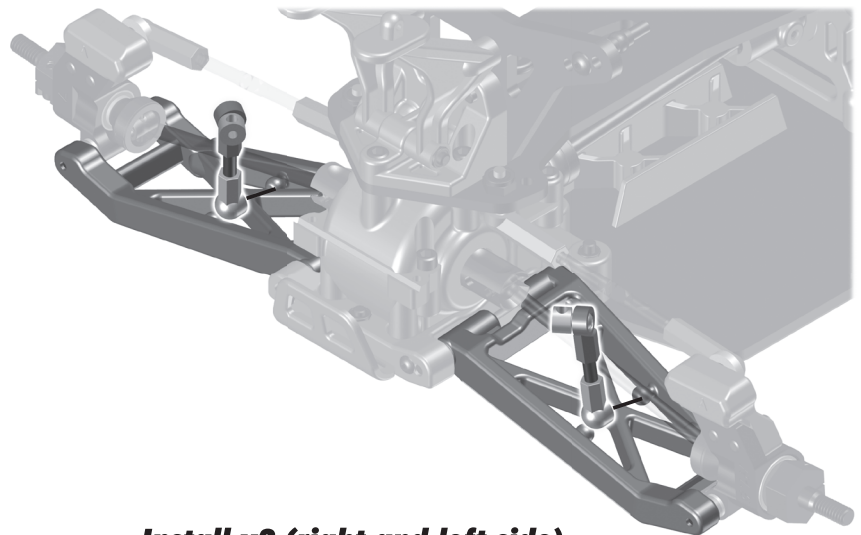
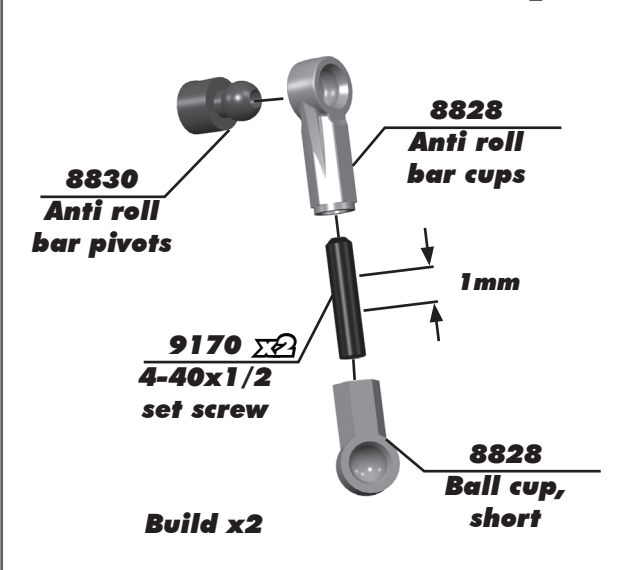

**:: Rear Anti Roll Bar Build - Step 2**

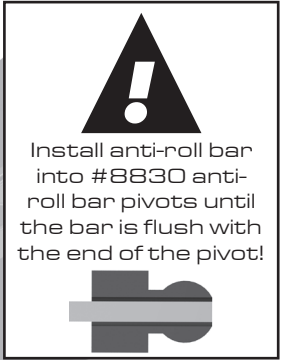
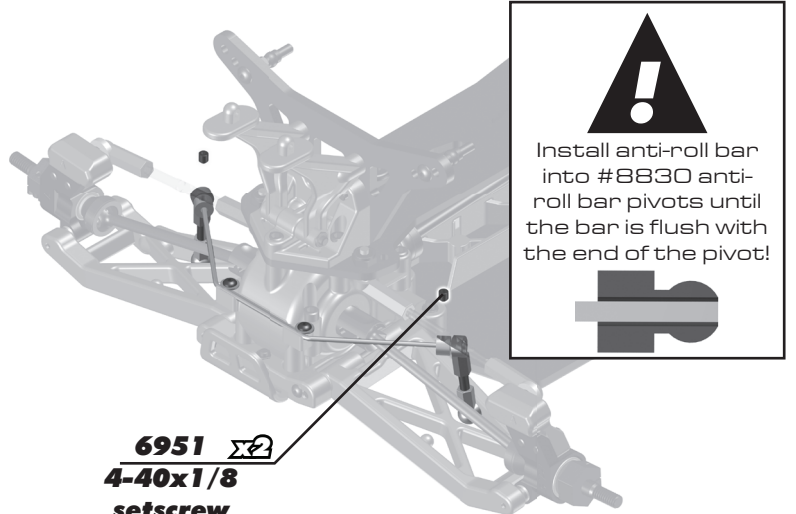
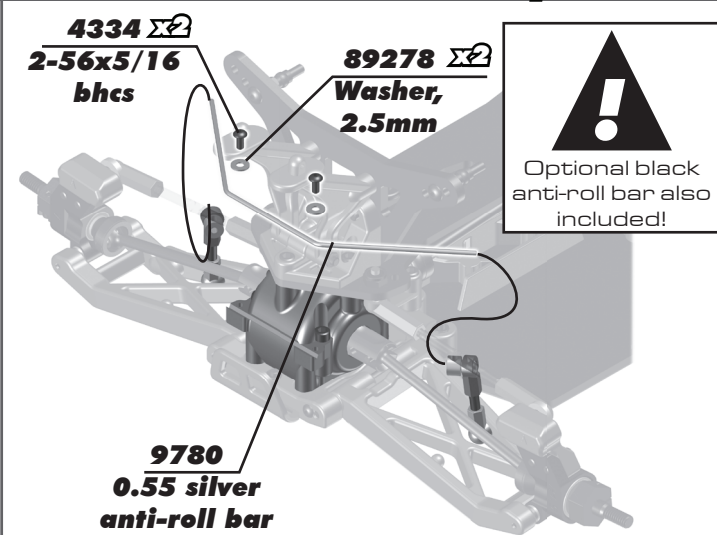

**:: Battery Tray and Side Body Mounts Build - Step 1**

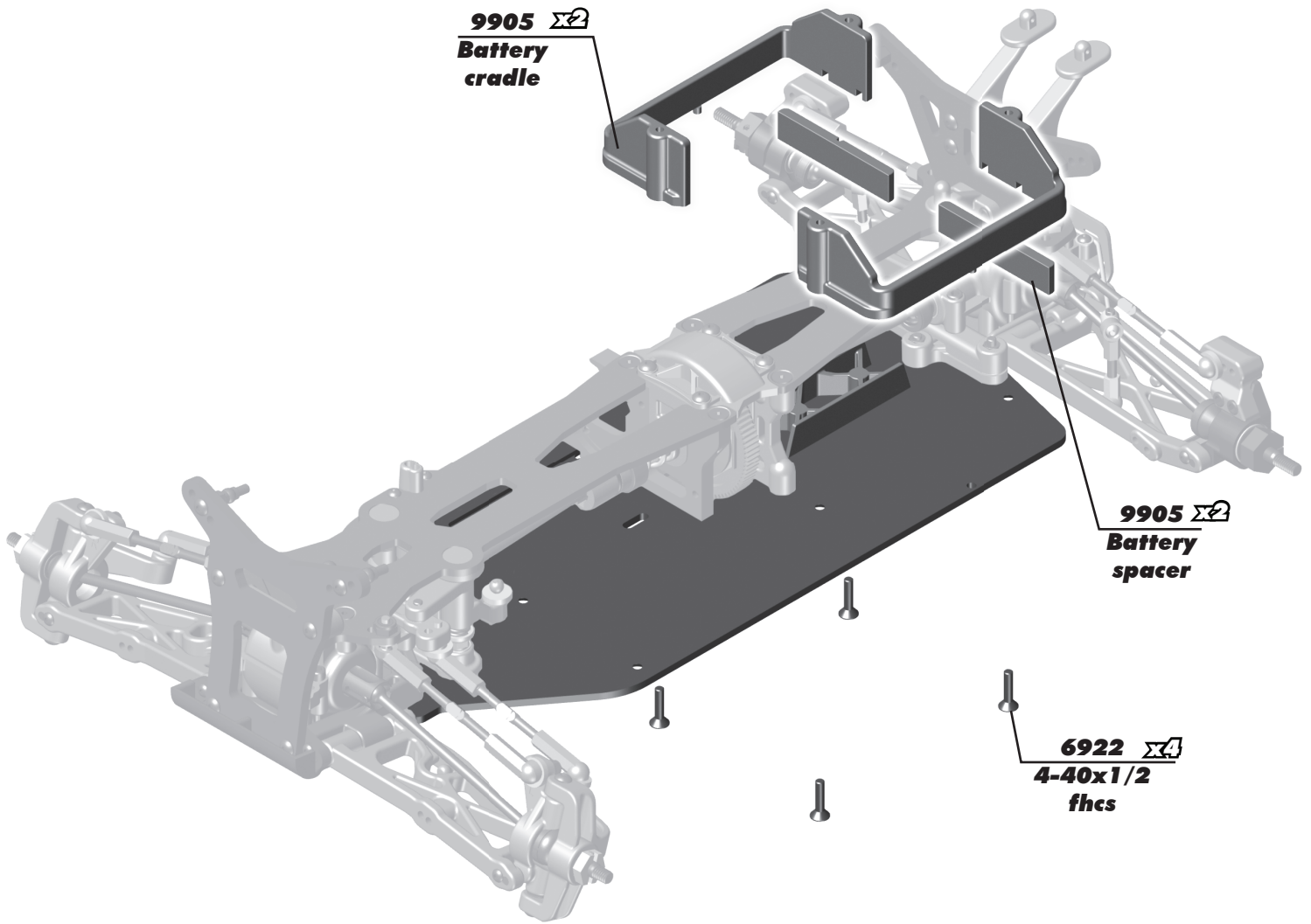

**:: Battery Tray and Side Body Mounts Build - Step 2**

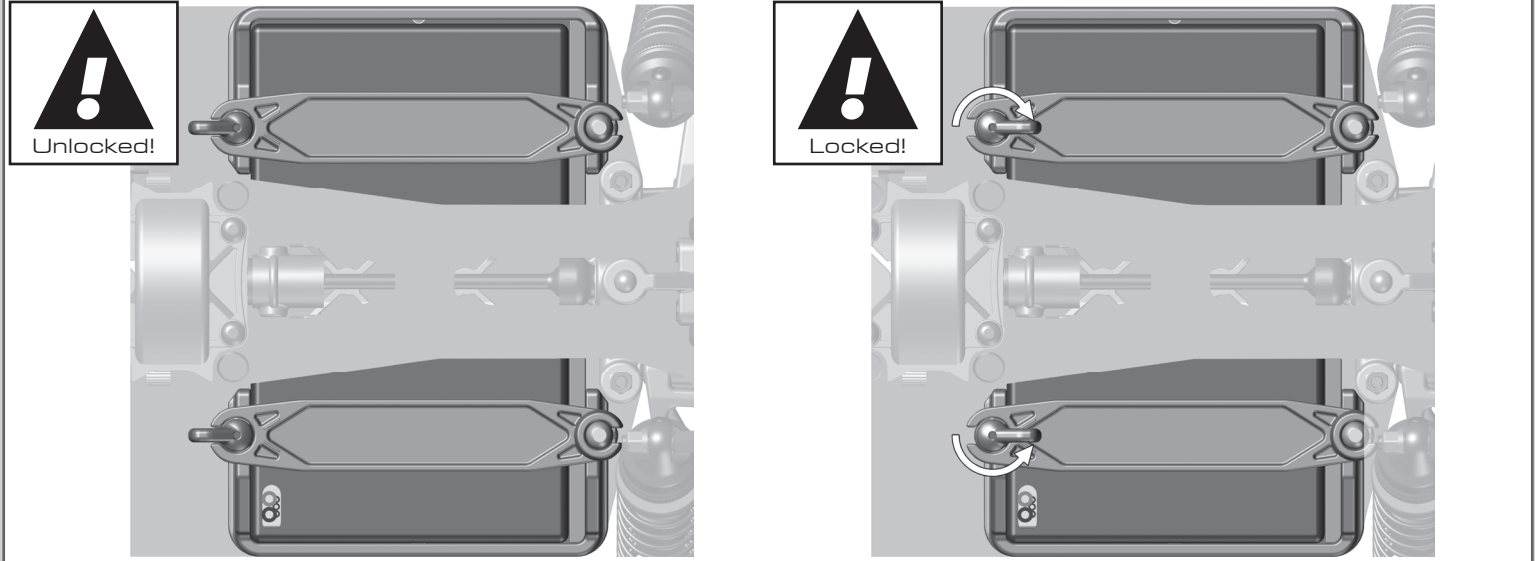

**:: Shocks Build - Step 1**

**91308**  
12mm shock piston  
(1.6 front)  
(1.7 rear)

**6299**  
1/8 E-clip

**91305**  
21x3 TiN shock shaft  
(front)

**91306**  
27.5x3 TiN shock shaft  
(rear)

**4187**  
Nylon spacer,  
(.030)

**Racers Tip:**  
Use a marker over the numbers on the pistons to make them easily visible!

**:: Shocks Build - Step 2**

**91299**  
12x23mm shock bodies  
(front)

**91301**  
12x31mm shock bodies  
(rear)

**5407**  $\Sigma 2$   
O-ring

**91309**  
Shock spacer

**91309**  $\Sigma 2$   
Shock hat bushing

**91309**  
12mm shock cap o-ring

**31327**  
VCS3 shock bottom cap o-ring

**31327**  
VCS3 shock bottom cap

**#1105 green slime**

**Racers Tip:**  
Lightly rub shock oil on the o-ring before installation!

**Racers Tip:**  
Coating the o-rings with green slime helps seal & reduce o-ring swell! Green slime not included in kit!

**1777**  
Shock eyelet

**1777**  
FT shock pivot ball

**:: Shocks Build - Step 3**

**Shock oil #5429**

**Front Shock: 35 wt**

**Rear Shock: 35 wt**

**91303 x4**  
12mm shock cap

**91309 x4**  
Shock cap o-ring

**31510 x4**  
M2x4mm bhcs

**Shock Bleeding Steps:**

1. Before assembly, get each bleed screw and thread it 1-2 turns into the shock cap. This will make installation easier when you are bleeding your shocks.
2. Pull shock shaft down.
3. Fill shock body 3/4 full with silicone shock fluid.
4. Slowly move the shock shaft up and down to remove air from under the piston.
5. Wait for bubbles to come to surface.
6. Fill shock body to top with silicone shock fluid.
7. Place a drop of oil in the cap and on cap threads.
8. Install cap (without bleed screw) and tighten completely.
9. Slowly compress shaft all the way to bleed excess silicone shock fluid out the hole in the cap (use rag around-shock to catch excess fluid).
10. Install M2x4mm button head screw until snug while shaft is fully compressed.

**Step 2-3**      **Step 4-5**      **Step 6-7**      **Step 8**      **Step 9-10**

**:: Shocks Build - Step 4**

**91304**  $\Sigma 4$   
12mm threaded collar o-ring

**91304**  $\Sigma 4$   
12mm threaded collar

**91330**  
12mm front spring, Blue (3.60lb)

**91337**  
12mm rear spring, white (2.10lb)

**91310**  
12mm shock spring cup (5mm offset)

**Front: 8mm**

**Rear: 5.5mm**

**Build x2 front and x2 rear shocks**

**! Racers Tip:**  
Use your finger to rub shock oil on the o-ring for smoother adjustment!

**:: Shocks Build - Step 5**

**6472**  $\Sigma 2$   
Shock mount nut

**6925**  $\Sigma 2$   
4-40x1/2 shcs

**6472**  $\Sigma 2$   
Shock mount nut

**6925**  $\Sigma 2$   
4-40x1/2 shcs

**! Use outside hole in front arm!**

**! Use inside hole in rear arm!**

**:: Servo Build - Step 1**

**Servo screw not included!**

**3981**  
Ballstud, .20 black, short

**Servo not included!**

**6272**  
Dust cover foam

**9180**  
Servo horn

**89007**  
Servo horn ring

**! Offset the servo horn by 5-10 degrees (approximately one notch)**

**1779**  $\Sigma 2$   
FT Servo mount

**7336**  $\Sigma 2$   
Servo spacers

**6917**  $\Sigma 2$   
4-40x3/8 bhcs

**7337**  $\Sigma 4$   
Gold washer

**:: Servo Build - Step 2**

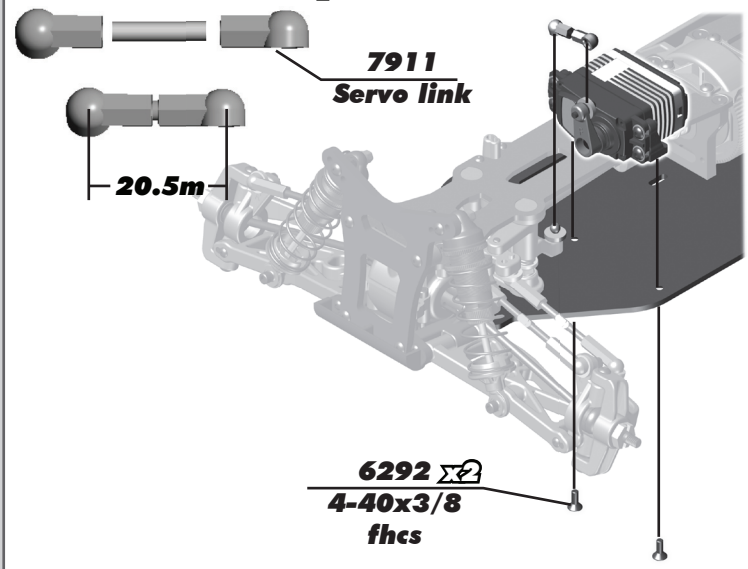

**:: Electronics Install - Step 1**

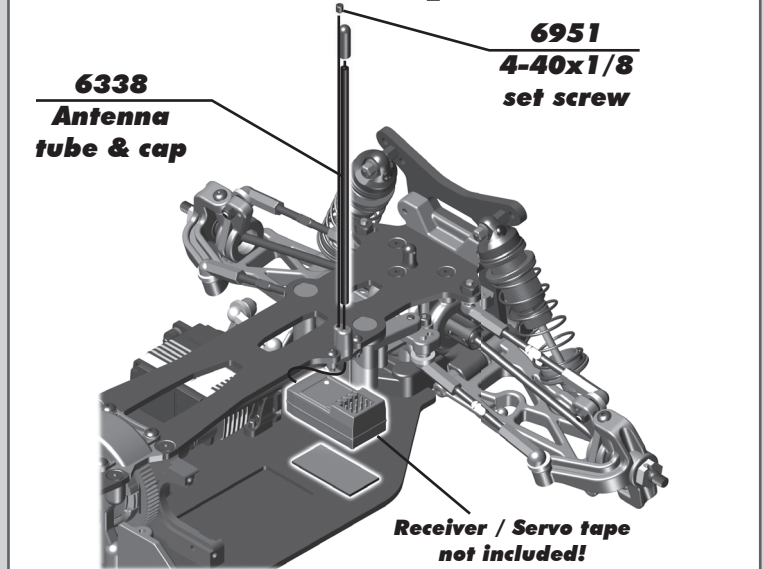

**:: Electronics Install - Step 2**

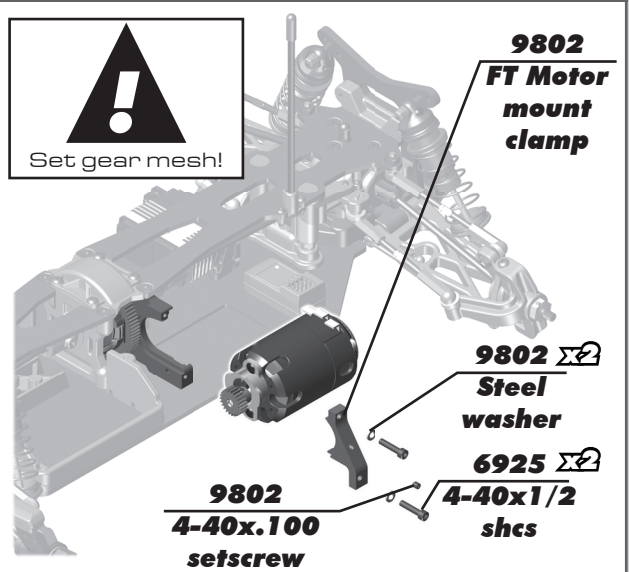
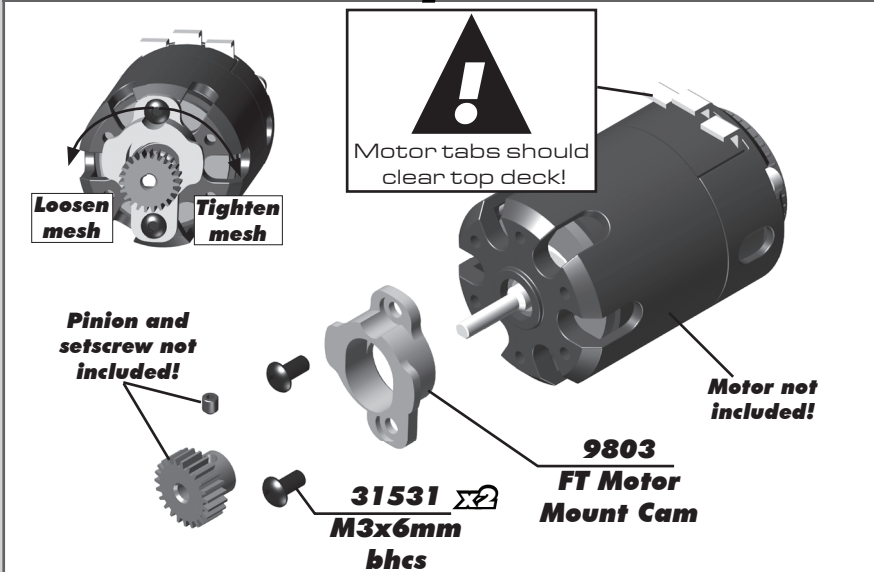

**:: Electronics Install - Step 3**

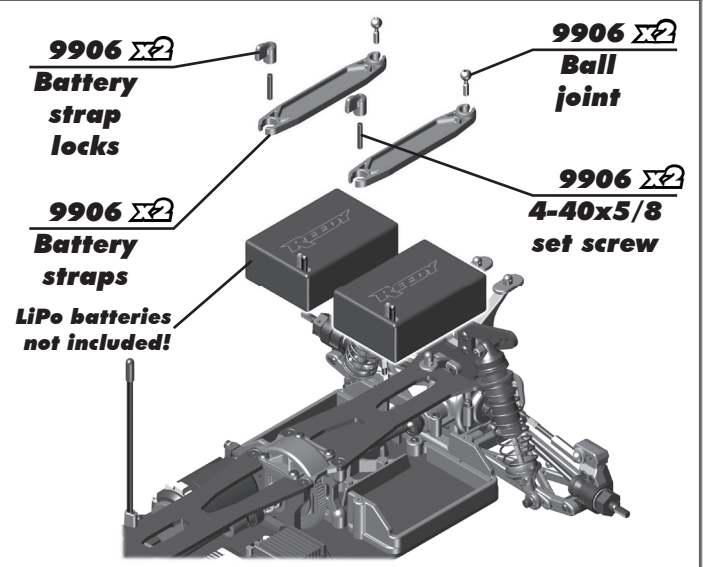
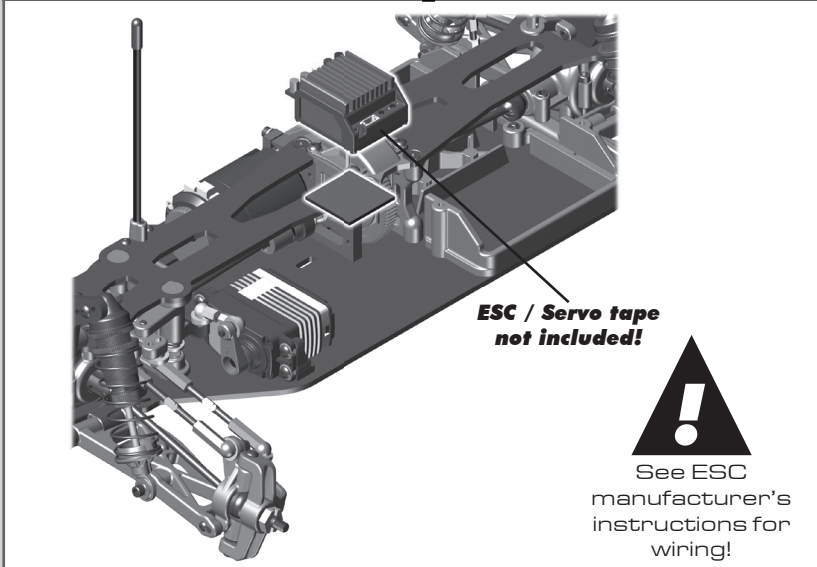

**:: Body, Wheels, Tires Install - Step 1**

**#1597**  
ca glue

**9767**  $\Sigma 2$   
**Buggy front wheel hex, white**

**Tires / Inserts not included!**

**! Carefully apply tire adhesive to the tire bead on both sides. Do one side at a time, allow it to dry before gluing the other side!**

**#1597**  
ca glue

**9695**  $\Sigma 2$   
**Buggy rear wheel hex, white**

**Tires / Inserts not included!**

**:: Body, Wheels, Tires Install - Step 2**

**6953**  $\Sigma 2$   
**8-32 LP steel locknut**

**6952**  $\Sigma 2$   
**8-32 locknut, steel**

**:: Body, Wheels, Tires Install - Step 3**

**! Remove the front bumper when installing chassis protective tape. Re-install front bumper when done.**

**9788**  
**Chassis protective sheet**

**! Trim along chassis edge!**

**:: Body, Wheels, Tires Install - Step 4**

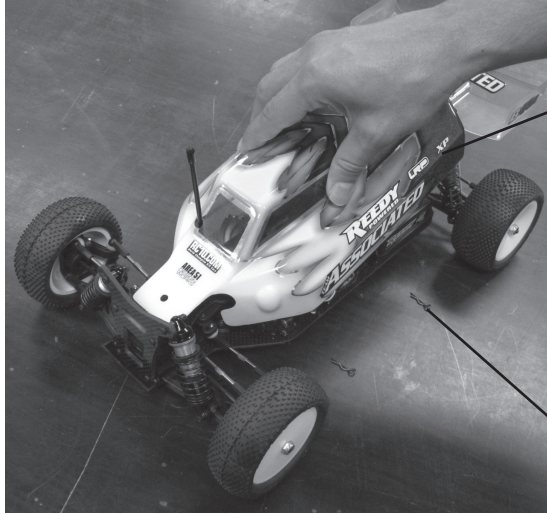

**#0248  
B44.2  
Finisher  
body by  
JConcepts**

**1736   
FT body  
clips, blue**

**Painting Tips:**

Body :  
Your B44.2 FT comes with a clear polycarbonate body. You will need to prep the body before you can paint it. Wash the inside thoroughly with warm water and liquid detergent. Dry the body using a clean, soft, lint-free cloth. Use the supplied window masks to cover the windows from the INSIDE of the body (RC cars get painted from the inside). Using high quality masking tape, apply tape to the inside of the body to create a design. Spray (either rattle can or airbrush) the paint to the inside of the body (preferably dark colors first, lighter colors last).

NOTE: use ONLY paint that is recommended for use with (polycarbonate) plastics. If you don't, you can destroy the plastic body!!!!).

After painting, cut the body along the trim lines. Make sure to drill or use a body reamer to make the holes for the body mounts and antenna!

**:: Body, Wheels, Tires Install - Step 5**

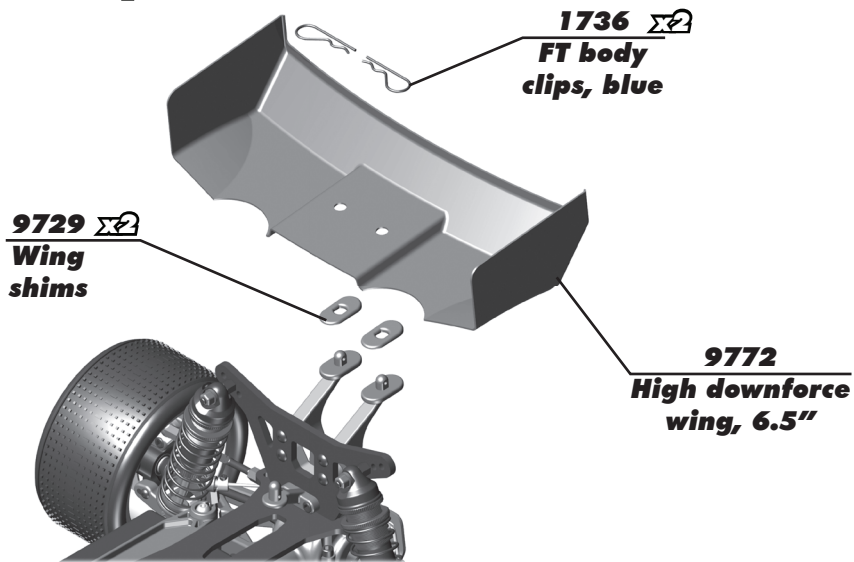

**9729   
Wing  
shims**

**1736   
FT body  
clips, blue**

**9772  
High downforce  
wing, 6.5"**

**:: Servo Chart**

**Steering Servo Chart**

		<b># 9180 servo arm </b>
<b>Associated</b>	<b>XP-1015, XP-1313</b>	<b>F</b>
<b>Airtronics</b>	<b>94102</b>	<b>A</b>
<b>Airtronics</b>	<b>94257, 94258, 94357, 94358, 94452, 94453, 94755</b>	<b>A</b>
<b>Hitec</b>	<b>HS-5625MG, HS-5645MG, HS645MG</b>	<b>H</b>
<b>Hitec</b>	<b>HS-965, HS-985MG, HS-5965, HS-5985MG</b>	<b>H</b>
<b>JR</b>	<b>Z4750, Z2750</b>	<b>J</b>
<b>JR</b>	<b>Z250, Z550</b>	<b>J</b>
<b>Futaba</b>	<b>S9204, S9250, S9450</b>	<b>F</b>
<b>Futaba</b>	<b>S9404</b>	<b>F</b>
<b>KO</b>	<b>PS-401, PS-2001, PS-2004, PS-2015, PS-2173, PS-2174, PS-2123, PS-2143, PS-2144</b>	<b>J</b>

\* Not all servo's are listed

\* Make sure servo linkage clears the servo through full travel in both directions.  
Use #7336 servo spacers to adjust the servos position

## :: Tuning Tips

### **Tips for Beginners:**

Before making any changes to the standard setup, make sure you can get around the track without crashing. Changes to your vehicle will not be beneficial if you can't stay on the track. Your goal is consistent laps.

Once you can get around the track consistently, start tuning your vehicle. Make only ONE adjustment at a time, testing it before making another change. If the result of your adjustment is a faster lap, mark the change on the included setup sheet (make additional copies of the sheet before writing on it). If your adjustment results in a slower lap, revert back to the previous setup and try another change.

When you are satisfied with your vehicle, fill in the setup sheet thoroughly and file it away. Use this as a guide for future track days or conditions.

### **Differential:**

Adjust the differential (A.K.A. 'diff' for short) as noted in the assembly instructions. Adjusting the rear diff is not meant to be a tuning option. If you can hear the diff making a "barking" or "chirping" sound on jump landings or under acceleration, either your diff is set too loose or your slipper clutch is set too tight. The front diff can go out 1/16" turn to get more steering.

### **Slipper Clutch:**

The assembly instructions give you a base setting for your clutch. To preserve the differentials, always start with the slipper on the loose side and slowly tighten the adjustment nut until it is set. To adjust the slipper, remove the body and insert a 2mm (or 5/64") hex wrench through the center of the top deck (or through the bottom slot in the chassis). Then, grab both of the rear wheels and rotate forwards to tighten and backwards to loosen. As you spin the wheels, you'll feel the motor click every 1/4 of a wheel revolution. At the track, tighten or loosen the nut in 2 click increments until you hear only a faint slipping sound for 1-2 feet on takeoffs.

### **Front Camber Link Length & Washers Under Ballstud:**

Changing the length of the camber link is considered a bigger step than adjusting the ballstud height. Typically shortening the camber link (or lowering the ballstud) will give the front end less roll and quicken steering response. Lengthening the camber link (or raising the ballstud) will give the front more roll and slower steering response. To raise the ballstud, remove washers from between the ballstud and upper deck.

### **Front Camber:**

A good starting camber setting is -1 degrees. Use the included #1719 camber gage to set your camber. Positive camber, where the top of the tire is leaning out, is typically not recommended.

### **Front Toe-In:**

Zero degree toe-in (tires pointing straight forward) is the setting that should be used in almost all track conditions. Occasionally you can increase turn in by adding a little toe-out (front of tires point slightly out). Front toe in is not a typical tuning adjustment used by The Team.

### **Front Arm Hole:**

The kit silver springs and outside front arm hole will work best in most cases. Moving the shock to the inside hole on the front arm requires you to add another down travel limiter to the front shocks, so there should be two down travel limiters in each shock. You should also change to a stiffer spring to account for the difference in leverage on the shock.

### **Front Ride Height:**

The standard front ride height setting is 21 mm. Check the ride height by lifting up the entire car about 8-12 inches off the bench and drop it. After the suspension "settles" into place, raise or lower the shock collars as necessary until there is 21 mm gap from the bottom of the chassis to the ground.

### **Anti-Squat:**

Anti-squat denotes the angle of the rear arms relative to the ground. Zero anti-squat means that the rear arms are flat, parallel with the ground. The kit setting is 2 degrees, and can be reduced to 1 degree by removing the included #4 washer underneath the arm mount. You can add another #4 washer so that there is two washers underneath the arm mount to get 3 degrees of anti-squat. Adding anti-squat tends to make the car "rotate" more in corners, but doesn't handle as well through the bumps. 1 degree will be better in bumpy sections.

### **Rear Camber Link Length & Washers under Ballstud:**

Changing the length of the camber link is considered a bigger step than adjusting the ballstud height on the rear chassis brace. Typically shortening the camber link (or lowering the ballstud) will give the rear end less roll and the car will tend to accelerate or "square up" better. Lengthening the camber link (or raising the ballstud) will give the rear more roll and more cornering grip. To raise the ballstud, remove washers from in-between the ballstud and upper deck. You should normally use the kit setting and only adjust the ballstud height.

## :: Tuning Tips (cont.)

### **Rear Hub Spacing:**

You have 3 options for rear hub spacing, FORWARD, MIDDLE, & BACK. The kit setting is FORWARD, which provides the most rear traction and will be used most often. For improved handling in bumps or rhythm sections, try moving the hubs to MIDDLE or BACK. This can also make the car handle better in 180 turns.

### **Rear Anti-Roll Bar:**

The #9780 B44 anti-roll bar kit (A.K.A. swaybar) allows you to add roll resistance to the rear end with minimal effect on handling over bumps and jumps. The anti-roll bar is very helpful when trying to tune the suspension. The black bar is the softest (.047" wire) and the silver (.055" wire) is the standard. It is popular to run a rear anti-roll bar in 4wd to help the car square up more out of turns.

### **Rear Arm Hole:**

The inner hole in the arm tends to work the best over the bumps and jump sections. Changing to the outer hole in the rear arm will tend to make the rear end feel more "locked in" and less responsive. Making this change to the outer hole requires you to remove the downtravel limiters from the rear shocks.

### **Rear Ride Height:**

The rear ride height setting you should use most often is 20 mm (the rear arms appear level when looking from the rear). Check the ride height by lifting up the entire car about 8-12 inches off the bench and drop it. After the suspension "settles" into place, raise or lower the shock collars as necessary until there is 20 mm gap from the bottom of the chassis to the ground. Note: Check the ride height gap at the rear end of the carbon fiber chassis, not at the rear chassis plate which is raised for more ground clearance. The chassis should look level from the side.

### **Battery Placement:**

The B44.2 battery cradle allows for quick battery spacing adjustment to fine tune the front to back weight distribution as needed. A simple rule of thumb to follow is, if your car pushes through the corner, shift the battery back & if it oversteers in the corner, move the battery forward.

### **Ackerman:**

"Ackerman" refers to the relative angle difference between the front wheels as they are turned to steer the car. More ackerman means that there is a greater difference in angle between the wheels, and the less ackerman you have the closer the wheels steer parallel to each other. The ackerman on the B44.2 can be adjusted by moving the steering rack ballstud forwards or back on the steering rack.

The steering ballstud in the back position on the rack (More Ackerman) will make the car more forgiving to drive, particularly in looser conditions.

The steering ballstud in the forward position on the rack (Less Ackerman) will make the car twitchier around center but will have more steering mid to corner exit.

### **Steering Rack:**



### **Setup Sheets:**

Most often, the best way to get your car handling right is to go to our website [www.rc10.com](http://www.rc10.com) and click on the links to Setup Sheets, then RC10B44.2 setups. Our team of professional drivers help develop these setups at National events. Also, most drivers have a "base" setup that they use as a starting point for every event. Try running some of our base setups OR look for track conditions and tires that are similar to your local track and mimic that setup. Remember, each adjustment has a purpose, so copy everything from the setup sheet and then make adjustments based on the recommendations in this manual.

**:: Shocks**

1777 FT Blue Aluminum Shock Pivot Ball with Eyelet	4 ea.
4187 .030 Nylon Washer	12
5407 Red O-Rings	8
6299 E-Clip	12
31327 VCS3 Shock Bottom Cap and O-Ring	2 ea.
31510 M2 x 4mm BHCS	6
91299 12X23mm FT Shock Bodies (front)	2
91301 12X31mm FT Shock Bodies (rear)	2
91303 12MM Shock Cap	2
91304 12MM Threaded Collar and O-Ring	2
91305 21X3mm TiN Shock Shaft (front)	1
91306 27.5X3mm TiN Shock Shaft (rear)	1
91308 12MM Shock Pistons, (1.5, 1.6, 1.7)	4 ea.
91309 12MM Shock Rebuild Kit	1
91310 12MM Shock Spring Cups (+0mm, +5mm, +9mm)	4 ea.
91314 12MM Shock (B4/B44 Front)	2
91316 12MM Shock (B4/B44 Rear)	2

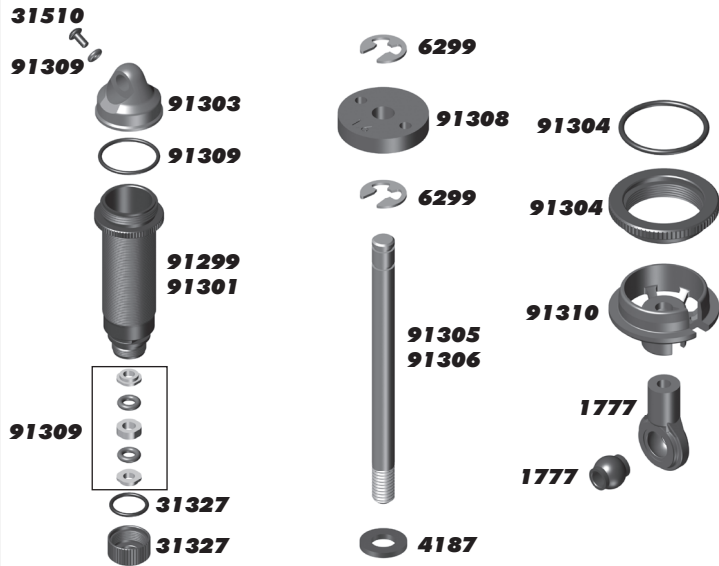

**:: Shock Springs**

91325 12MM Front SPRING BRN 2.85	Pr.
91326 12MM Front SPRING BLK 3.00	Pr.
91327 12MM Front SPRING GRN 3.15	Pr.
91328 12MM Front SPRING WHT 3.30	Pr.
91329 12MM Front SPRING GRY 3.45	Pr.
91330 12MM Front SPRING BLU 3.60	Pr.
91331 12MM Front SPRING YLW 3.75 - Kit	Pr.
91332 12MM Front SPRING RED 3.90	Pr.
91333 12MM Front SPRING ORN 4.05	Pr.
91334 12MM Front SPRING PRL 4.20	Pr.
91335 12MM Rear SPRING BLK 1.90	Pr.
91336 12MM Rear SPRING GRN 2.00	Pr.
91337 12MM Rear SPRING WHT 2.10 - Kit	Pr.
91338 12MM Rear SPRING GRY 2.20	Pr.
91339 12MM Rear SPRING BLU 2.30	Pr.
91340 12MM Rear SPRING YLW 2.40	Pr.
91343 12MM Front SPRING KIT, 4WD Buggy	1
91344 12MM Rear SPRING KIT	1



**:: Differentials**

2330 Diff T-nut	2
3911 Trans. Shim Set	1
3914 Differential Ring Gear & Drive Pinion Gear	1
3976 3/8 x 5/8 RS Ball Bearing	2
6573 Diff Thrust Washer & Bolt	1
6574 5/64 Diff Thrust Balls	6
6579 Diff Drive Rings	2
6581 3/32 Carbide Diff Balls	12
6582 Diff Thrust Spring	1
6909 Diff Bearing 3/16 x 5/16	2
9734 B44 Outdrives, Set	1

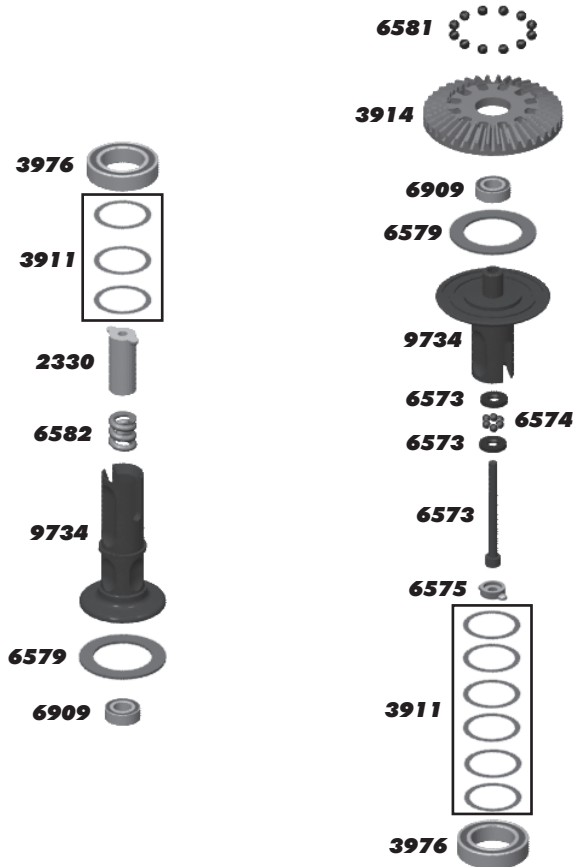

**:: Shock Oil**

5420 10 Weight Silicone Shock Oil	2oz.
5421 20 Weight Silicone Shock Oil	2oz.
5422 30 Weight Silicone Shock Oil	2oz.
5423 40 Weight Silicone Shock Oil	2oz.
5424 22.5 Weight Silicone Shock Oil	2oz.
5425 80 Weight Silicone Shock Oil	2oz.
5426 27.5 Weight Silicone Shock Oil	2oz.
5427 15 Weight Silicone Shock Oil	2oz.
5428 25 Weight Silicone Shock Oil	2oz.
5429 35 Weight Silicone Shock Oil	2oz.
5430 45 Weight Silicone Shock Oil	2oz.
5431 55 Weight Silicone Shock Oil	2oz.
5432 32.5 Weight Silicone Shock Oil	2oz.
5433 37.5 Weight Silicone Shock Oil	2oz.
5434 42.5 Weight Silicone Shock Oil	2oz.
5435 50 Weight Silicone Shock Oil	2oz.
5436 60 Weight Silicone Shock Oil	2oz.
5437 70 Weight Silicone Shock Oil	2oz.
5438 47.5 Weight Silicone Shock Oil	2oz.



**:: Slipper / Spur Gears / Pinions**

1654	FT Axle Pins	4
7485	FT V2 Slipper Hubs	2
7486	FT V2 Slipper Spring and Washer	1
7935	.187 x .50 x .196" Bearing	2
9603	Slipper Pad	2
9649	72T 48P Spur Gear	1
9650	75T 48P Spur Gear	1
9651	81T 48P Spur Gear (Kit)	1
9652	78T 48P Spur Gear	1
9653	84T 48P Spur Gear	1
9711	B44 Bearing Insert	2
9740	B44 Slipper Nut	1
9741	Slipper Nut O-Ring	6
9742	B44 Slipper Drive Cups	1
9910	B44.2 Slipper Shaft	1
91175	FT VTS Slipper Conversion	1
91176	VTS Slipper Housing	1
91177	VTS Slipper Pads	2
91178	VTS Slipper Plate	1
91179	FT VTS Slipper Hub, outer	1

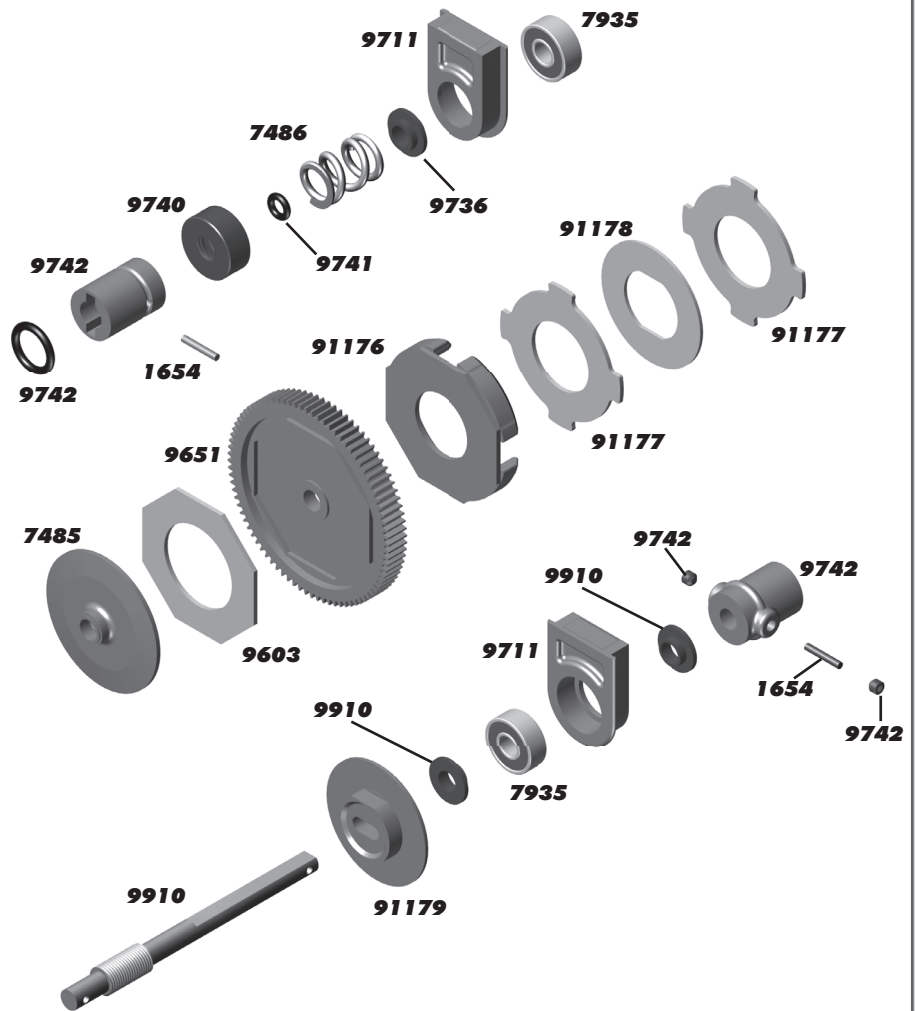

**:: Pinions**

8253	16T 48P Pinion Gear	1
8254	17T 48P Pinion Gear	1
8255	18T 48P Pinion Gear	1
8256	19T 48P Pinion Gear	1
8257	20T 48P Pinion Gear	1
8258	21T 48P Pinion Gear	1
8259	22T 48P Pinion Gear	1
8260	23T 48P Pinion Gear	1
8261	24T 48P Pinion Gear	1
8263	26T 48P Pinion Gear	1
8264	27T 48P Pinion Gear	1
8265	28T 48P Pinion Gear	1
8266	29T 48P Pinion Gear	1
8267	30T 48P Pinion Gear	1
8268	31T 48P Pinion Gear	1
8269	32T 48P Pinion Gear	1
8270	33T 48P Pinion Gear	1
8271	34T 48P Pinion Gear	1
8272	35T 48P Pinion Gear	1

**:: Anti-Roll Bars**

6951	4-40 x 1/8" Set Screw	6
8828	Anti Roll Bar Cups, Set	1
8830	Anto Roll Bar Pivots (with setscrews), Set	1
9170	Adjustable Servo Link (contains setscrew)	1
9780	B44 Anti Roll Bar Kit	1



**:: Turnbuckles**

1404	FT Blue Titanium Turnbuckles 1.775" / 45mm	Pr.
1406	FT Blue Titanium Turnbuckle 2.00 / 51mm"	Pr.
7230	Ball Cups, Large	12

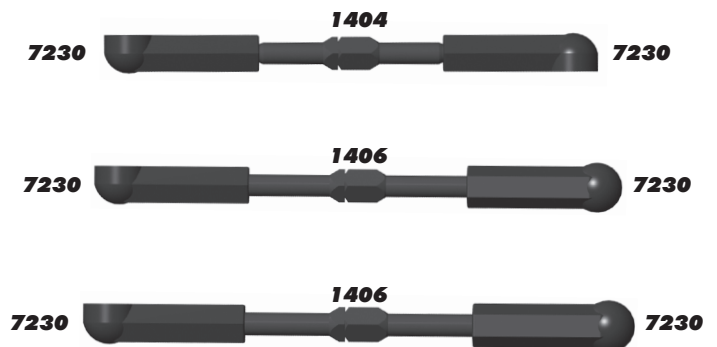

**:: Front and Rear Gearboxes**

3903	Drive Pinions	2
3911	Trans. Shim Set	1
3919	Input Shaft Hardware	1
3977	3/16 x 3/8" RS Ball Bearing	2
4334	2-56 x 5/16" BHCS	8
6299	1/8" Small E-Clips	12
6860	FT 4-40 x 3/8" SHCS, blue	6
7381	CVD Rebuild Kit	1
7996	CVA Pin Retainer	2
9733	B44 Transmission Case	1
9747	B44 Front CVA Bone	2
9761	B44 CVA Input Shaft	1
9780	B44 Anti Roll Bar Kit	1
9911	B44.2 Rear CVA Bone	1
89278	Washer, 2.5mm	20

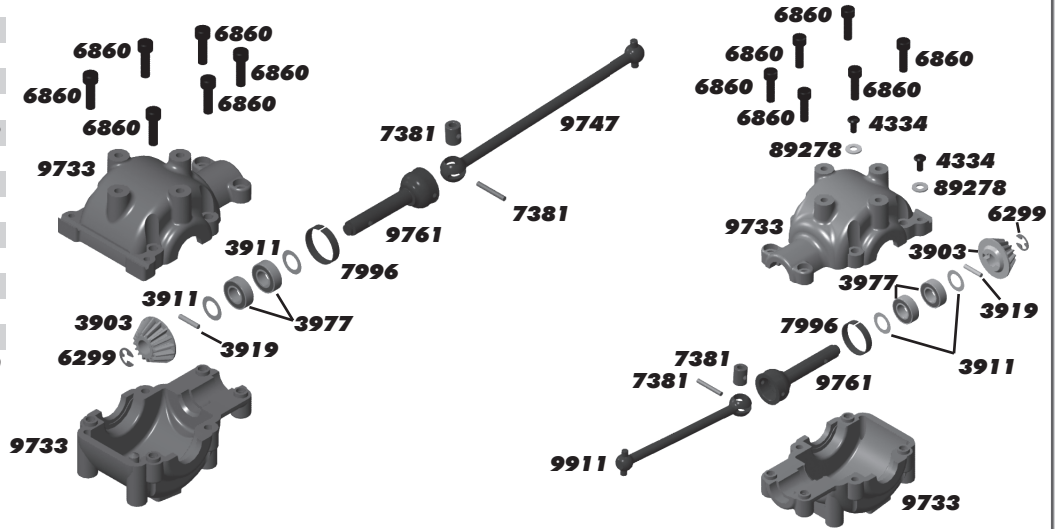

**:: Steering**

1779	FT Servo Mount, blue	0
3874	Block Carrier Bushings	4
3981	Ballstud .20" Black, short	6
6272	Foam Ballend Dust Covers	28
6276	Ballstud .20" Silver, short	6
6277	Ballstud .30" Silver, short	6
6292	4-40 x 3/8" FHCS	6
6917	4-40 x 3/8" BHCS	6
7336	Steering Servo Mount Kit	1
7337	.250 x .125 x .015" Washer	4
7911	Steering Servo Link	1
9180	Servo Horns, Molded	1
9630	Ballstud Washer	10
9743	B44 Steering Set	1
9744	B44 Steering Hardware	1
9746	B44 Steering Bearing Set	1
89007	Steering Servo Ring, blue	1



**:: Front and Rear Shock Towers**

1736	FT Body Clips, Short, blue	6
1780	FT Blue Alum. Shock Bushing, std	4
4449	4-40 x 3/16" Alum. Locknut	5
6472	4-40/5-40 Plastic Nut	4
6917	4-40 x 3/8" BHCS	6
7413	4-40 x 3/4" BHCS	6
7738	4-40 x 7/8" SHCS	6
7874	4-40 x 7/16" SHCS	8
9719	B44 Body Mounts	1
9729	B44 Wing Mounts	1
9772	High Downforce Wing 6.5"	1
9903	B44.2 Front Shock Tower	1
9904	B44.2 Rear Shock Tower	1

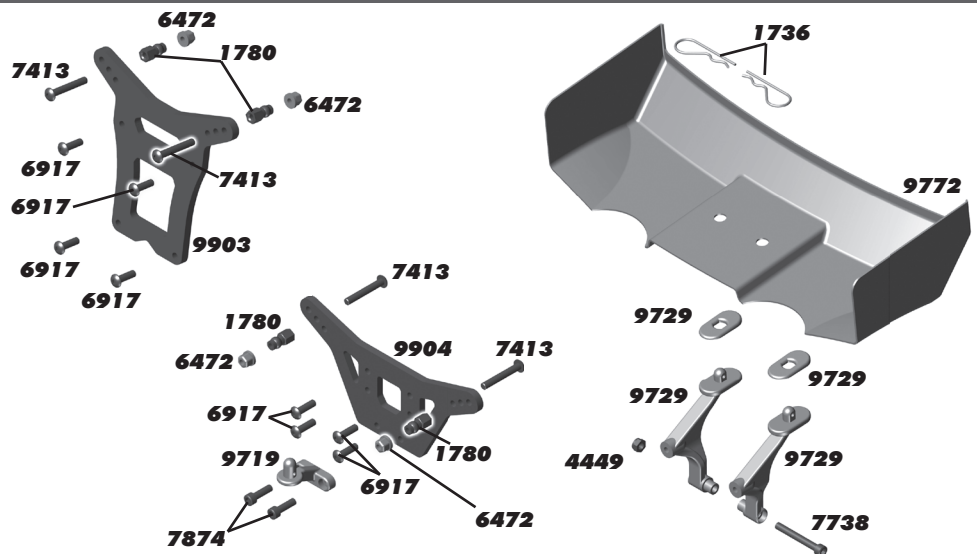

**:: Front and Rear Top Plates**

1736	FT Body Clips, Short, blue	6
4334	2-56 x 5/16" BHCS	8
4449	4-40 x 3/16" Alum. Locknut	5
6277	Ballstud .30" Silver, short	6
6288	4-40 x 1/4" BHCS	6
6292	4-40 x 3/8" FHCS	6
6338	Antenna Tube 12", black	1
6917	4-40 x 3/8" BHCS	6
6925	4-40 x 1/2" SHCS	6
6936	Washers, Alum. #4	10
6951	4-40 X 1/8" Set Screw	6
9714	B44 Shock Tower Mounts	1
9719	B44 Body Mounts	1
9901	B44.2 Front Top Deck	1
9902	B44.2 Rear Top Deck	1
9913	Antenna Mount	1

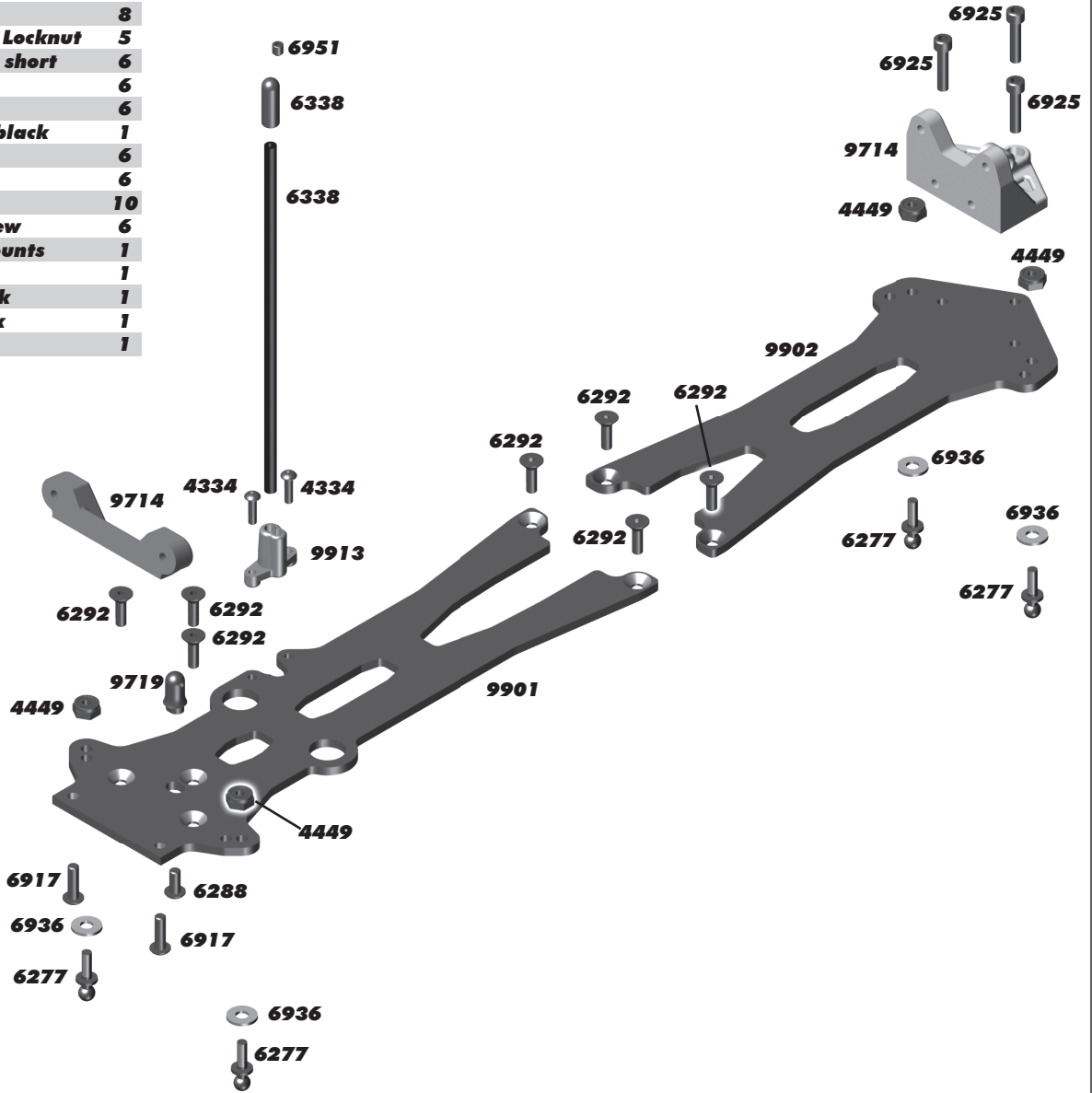

**:: Center Bulkhead and Motor Mount**

2221	4-40 x 7/16" BHCS	6
6292	4-40 x 3/8" FHCS	6
6925	4-40 x 1/2" SHCS	6
9709	B44 Center Bulkhead	1
9800	B44 FT Cam Motor Mount Set	1
9801	B44 FT Cam Motor Mount	1
9802	B44 FT Motor Mount Clamp	1
9803	B44 FT Motor Mount Cam	1
9913	B44.2 Center Bulkhead Brace	1
31531	M3 x 6mm BHCS	6

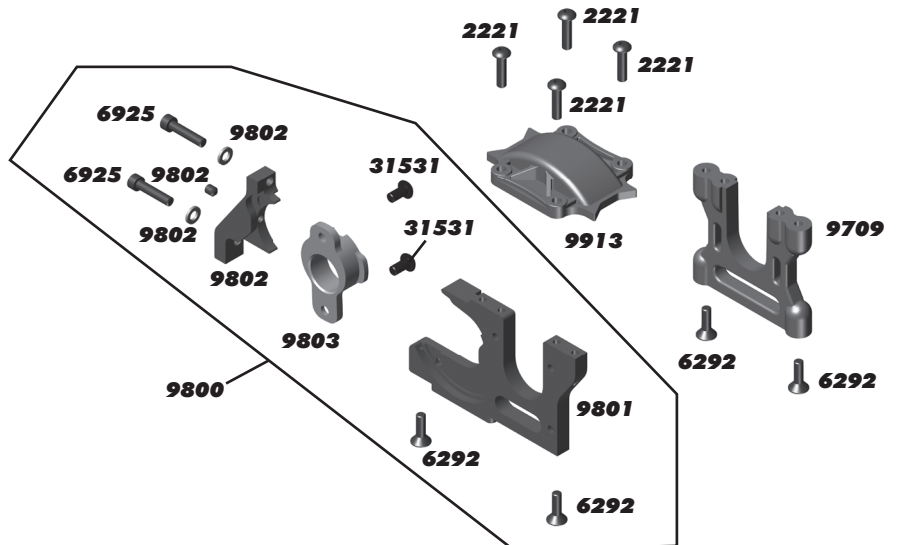

**:: Front Suspension**

2221	4-40 x 7/16" BHCS	6
3977	3/16 x 3/8" RS Ball Bearing	2
3983	Ballstud .30" Black, short	6
4449	4-40 x 3/16" Alum. Locknut	5
6272	Foam Ballend Dust Covers	28
6277	Ballstud .30" Silver, short	6
6925	4-40 X 1/2" SHCS	6
6953	8-32 LP Steel Locknut	6
7369	1/16" Universal Roll Pins	4
7381	CVD Rebuild Kit	1
7996	PosiLock QC Pin Retainer	2
9645	2-56 x 1/8" BHCS	6
9647	B44 Steering Block Bushing	4
9715	B44 Front Arms	Pr.
9716	B44 Hinge Pin Set	1
9720	B44 Caster Block	Pr.
9722	B44 Steering Block	Pr.
9747	B44 Front CVA BoneB44	2
9748	Front CVA Axle	2
9750	B44 Axle Drive Hex	2
9751	B44 Front Crush Tube	2

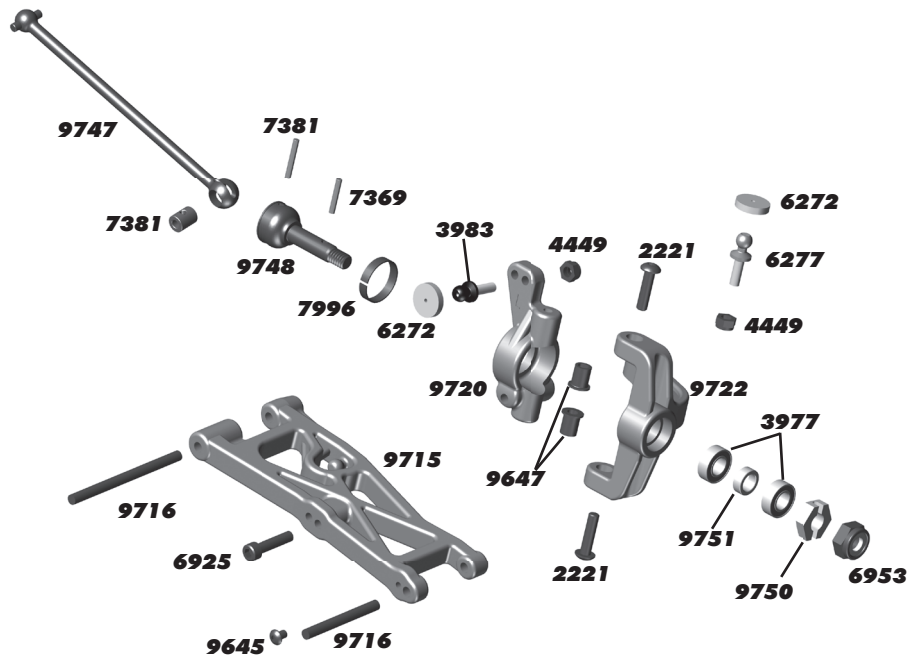

**:: Rear Suspension**

3977	3/16 x 3/8" RS Ball Bearing	2
3983	Ballstud .30" Black, short	6
6272	Foam Ballend Dust Covers	28
6925	4-40 X 1/2" SHCS	6
6932	4-40 x 5/16" SHCS	6
6952	8-32 Locking Nut, Steel	6
7368	3/16" Axle Shims	14
7369	1/16" Universal Roll Pins	4
7381	CVD Rebuild Kit	1
7933	Crush Tube GT2	2
7935	.187 x .50 x .196" Bearing	2
7996	PosiLock QS Pin Retainer	2
9630	Ballstud Washer	10
9645	2-56 x 1/8" BHCS	6
9660	2-56 x 7/32" SHCS	6
9716	B44 Hinge Pin Set	1
9754	B44 Rear CVA Bone	2
9764	B44 Rear Arm	Pr.
9864	B44 FT Aluminum Hub, 0°	Pr.
9872	B44 FT Aluminum Hub Tower Set	1
9890	12mm Aluminum Clamping Wheel Hex, Buggy Rear	2
31286	Alum. Ballstud Washer (1mm, 2mm)	4 ea.

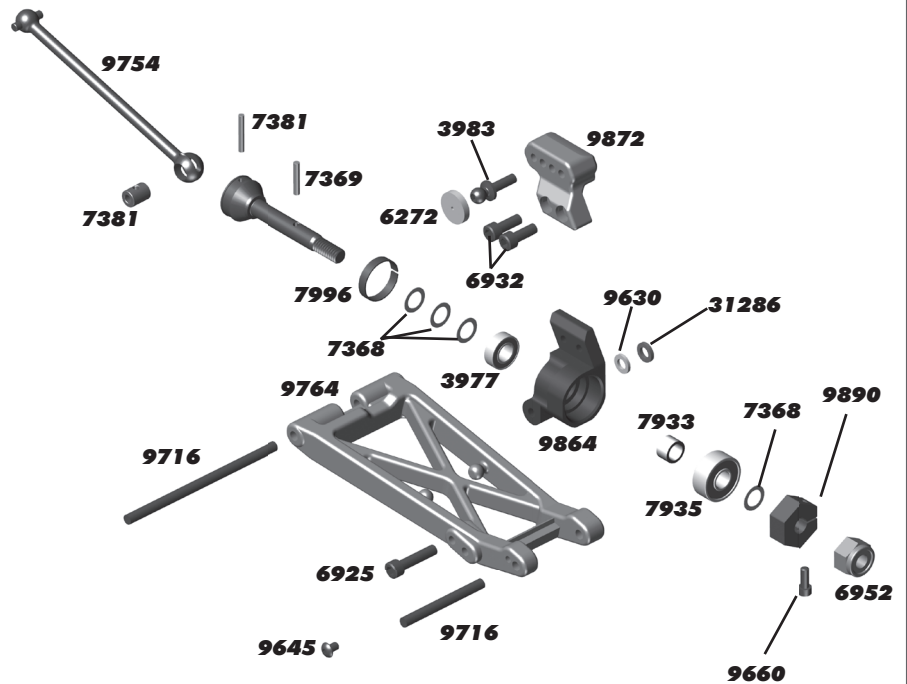

**:: Chassis and Battery Mounts**

4449	4-40 x 3/16" Alum. Locknut	5
6292	4-40 x 3/8" FHCS	6
6915	4-40 x 5/8" FHCS	6
6917	4-40 x 3/8" BHCS	6
6922	4-40 X 1/2" FHCS	6
6936	Washers, Alum. #4	10
7673	4-40 x 5/16" FHCS	6
9645	2-56 x 1/8" BHCS	4
9713	B44 Front Bulkhead	1
9717	Front Hinge Pin Brace	1
9718	B44 Front & Rear Bumper	1 ea.
9726	B44 Rear Chassis Plate, 3° arm mount	1
9765	4-40 x 7/16" FHCS	6
9788	Protective Sheef B4/B44	1
9900	B44.2 Chassis	1
9905	B44.2 Battery Cradle	1
9906	B44.2 Battery Straps	1

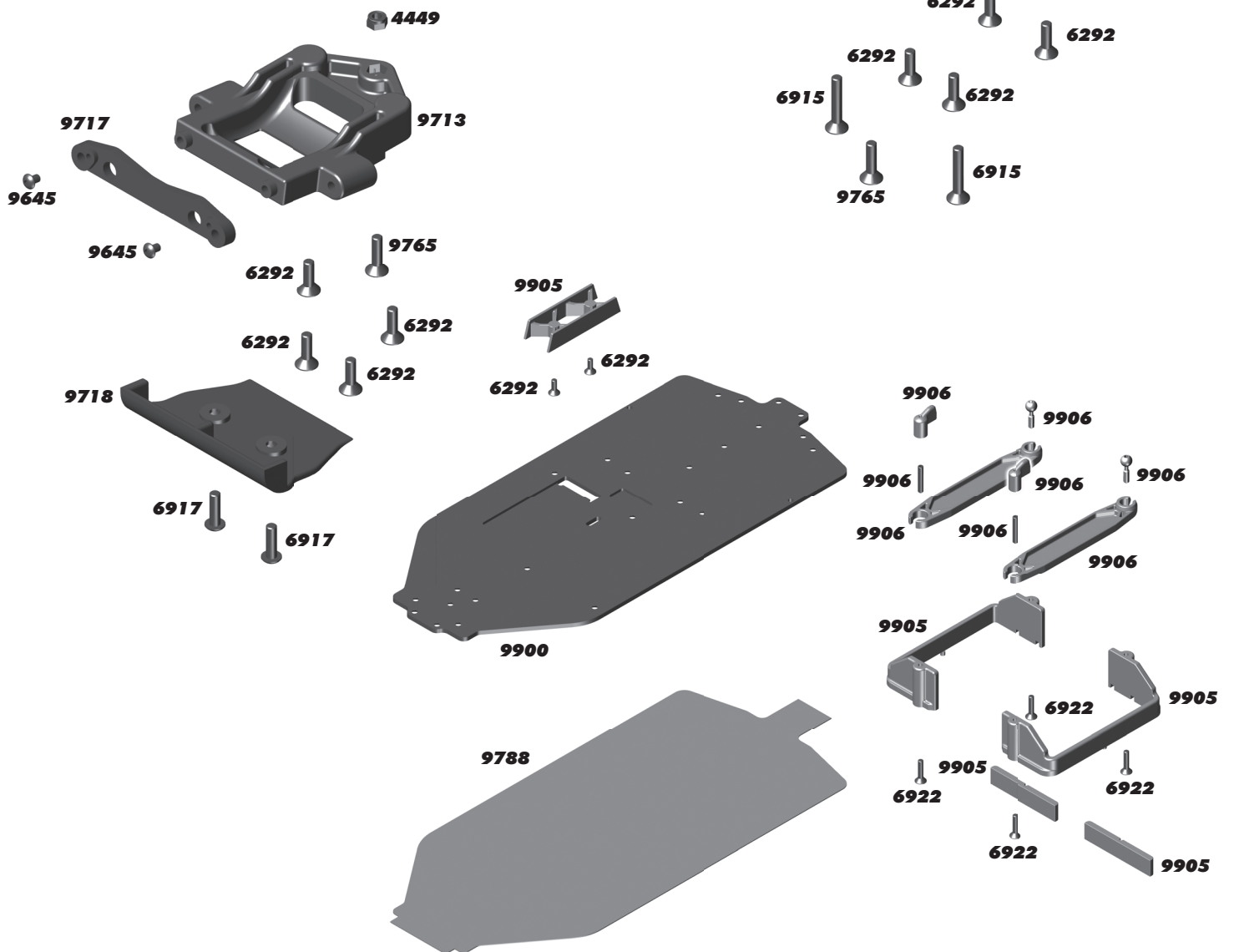
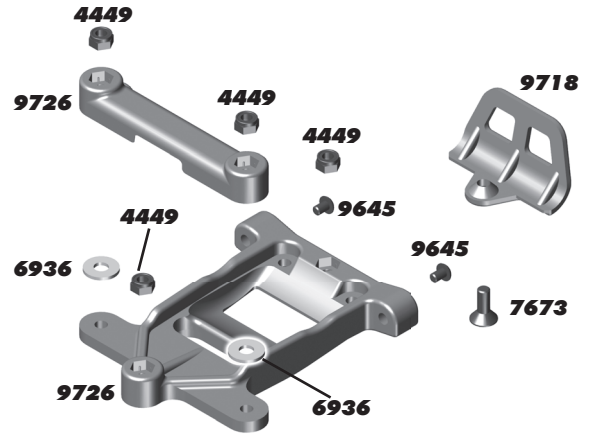

**:: Factory Team and Option Parts**

1404	Ti Turnbuckle 1.775" Blue	2
1406	Ti Turnbuckle 2.00" Blue	2
1411	Ti Turnbuckle 0.75" Blue	2
1654	FT Solid Axle Pins	4
1734	FT Blue Body Clips, 4 Long, 6 Short	1
1735	FT Blue Body Clips, Long	4
1736	FT Blue Body Clips, Short	6
1777	FT Blue Aluminum Ball/Eyelet Set	1
1779	FT Servo Mount Blue Aluminum	2
1780	FT Aluminum Shock Bushing	4
1787	Battery Strap Thumbscrew	2
3911	Transmission Shim Set	1
6584	3/32" Ceramic Diff Balls	12
6860	4-40 x 3/8" SH Screw, Blue Alum.	6
6906	3/16 x 3/8" PTFE Bearings	Pr.
6937	FT Blue 4-40 Locknuts	6
6943	FT Blue 8-32 Locknuts	4
9721	B44 Alum. Caster Blocks	Pr.
9733	Transmission Case, top and bottom	1
9734	FT Outdrive	1
9742	Slipper Drive Cup	1
9776	FT B44.1 Ballast Weight	1
9779	FT B44 Complete Bearing Set	1
9783	B44 Alum. Front Tower Mount	1
9784	B44 Alum. Rear Tower Mount	1
9787	Chassis Protective Sheet	1
9795	Ti Nitride Ballstuds 4-40 x 0.20" Long	2
9796	Ti Nitride Ballstuds 4-40 x 0.30" Long	2
9797	Ti Nitride Ballstuds 4-40 x 0.40" Long	2
9798	Ti Nitride Ballstuds 4-40 x 0.20" Short	2
9799	Ti Nitride Ballstuds 4-40 x 0.30" Short	2
9864	B44 FT Aluminum Hub, 0° - Kit	Pr.
9865	B44 FT Aluminum Hub, 0.5°	Pr.
9866	B44 FT Aluminum Hub, 1°	Pr.
9867	B44 FT Aluminum Hub, 1.5°	Pr.
9872	B44 FT Aluminum Hub Tower Set	1
9873	FT Aluminum Hub Tower C, graphite	2
9890	12mm Alum. Clamping Wheel Hex, Buggy Rear	2
31286	FT Ballstud Washer, Aluminum 1mm, 2mm each	1
91170	FT High Torque Slipper Pad	2

**:: XP Electronics**

29107	S1903 Metal Gear Set	1
29125	S1903MG Servo	1
29126	S2008MG Servo	1
29141	XP SC450-BL Brushless ESC	1
29142	XP ESC Fan Option	1
29143	XP SC700-BL Brushless ESC	1
29166	XP DS1313 Digital Servo	1
29167	XP DS1015 Digital Servo	1
29209	Gear Set, DS1313	1
29210	Gear Set, DS1015	1
29211	Servo Case, DS1313 / DS1015	1
29212	Accessory Pack, DS1313 / DS1015	1
29214	TRS403-SSi 2.4GHz 4Ch Receiver	1
29215	XP2G 2.4GHz Radio System	1
29216	XP3G 2.4GHz Radio System	1
29217	TRS402-SSi 2.4GHz 4Ch Receiver	1
29218	XP2-SSi 2.4GHz Radio System	1
29221	XP3SS 2.4GHz Radio System	1
29222	TRS401SS 2.4GHz 4Ch Receiver	1

**:: Reedy Batteries**

302	AA Alkaline 1.5V (4)	1
303	AA 2700mAh NiMH 1.2V Rechargeable	1
627	LiPo 60C 5200mAh 7.4V SP	1
632	TX Lightweight Battery 1350mAh 11.1V	1
633	TX Battery - 3PK, M11 3000mAh 11.1V	1
634	TX Battery - Helios, Z1 2400mAh 11.1V	1
637	TX Battery - M11X 2500mAh 7.4V	1
686	LiPo 40C+ 4200mAh 7.4V SP	1
737	Wolfpack LiPo 4800mAh 7.4V 25C S.P.	1

**:: Reedy Motors and ESC's**

908	Replacement Rotor 540-SL	1
920	540-SL Brushless Motor 3300kV	1
921	540-SL Brushless Motor 3900kV	1
922	540-SL Brushless Motor 4900kV	1
923	540-SL Brushless Motor 6100kV	1
940	Sonic 540 21.5 Competition Brushless Motor	1
941	Sonic 540 17.5 Competition Brushless Motor	1
941S	Sonic 540 17.5 Replacement Stator	1
942	Sonic 540 13.5 Competition Brushless Motor	1
943	Sonic 540 10.5 Competition Brushless Motor	1
944	Sonic 540 9.5 Competition Brushless Motor	1
945	Sonic 540 8.5 Competition Brushless Motor	1
946	Sonic 540 7.5 Competition Brushless Motor	1
947	Sonic 540 6.5 Competition Brushless Motor	1
948	Sonic 540 5.5 Competition Brushless Motor	1
949	Sonic 540 5.0 Competition Brushless Motor	1
950	Sonic 540 4.5 Competition Brushless Motor	1
951	Sonic 540 4.0 Competition Brushless Motor	1
952	Sonic 540 3.5 Competition Brushless Motor	1
954	Sonic 540 Stock Rotor 12.3 x 24.2 (7.25)	1
955	Sonic 540 Stock Rotor 12.3 x 25.0 (7.25)	1
956	Sonic 540 Stock Rotor 12.5 x 25.0 (7.25)	1
957	Sonic 540 Modified Rotor 12.2 x 25.0 (5.0)	1
958	Sonic 540 Modified Rotor 12.5 x 25.0 (5.0)	1
987	Sonic 540 Modified Rotor 12.5 x 25.0 (5.0)	1

**:: Reedy Accessories**

604	526-S AC/DC 2S-6S LiPo/LiFe Charger	1
605	Motor Cooling Fans (2)	1
606	Charge Harness 2S Saddle Pack 4mm	1
607	Charge Harness 2S Standard Pack 4mm	1
654	4.0mm plugs (2M, 2F)	1
655	4.0mm plugs (2M, 10F)	1
656	4.0mm plugs (10F)	1
658	4.0mm plugs (10M)	1
659	4.0mm plugs (30M)	1
660	3.5mm plugs (3M, 3F)	1
661	3.5mm plugs (10F)	1
663	3.5mm plugs (10M)	1
664	3.5mm plugs (30M)	1
716	Reedy 09 Decal Set	1
959	Sonic 540/550 Sensor w/Bearing	1
960	Sonic 540/550 Insulator Set (2 pcs.)	1
961	Sonic 540/550 Timing Cap w/Screws	1
962	Sonic 540 Case Screws (3 pcs.)	1
972	Sonic 540 Steel Bearing Set	1
973	Sonic 540 Ceramic Bearing Set	1
974	540-SL/550-SL Steel Bearing Set	1
975	540-SL/550-SL Ceramic Bearing Set	1
978	Flat Sensor Wire 70mm	1
979	Flat Sensor Wire 110mm	1
980	Flat Sensor Wire 150mm	1
981	Flat Sensor Wire 200mm	1
982	Flat Sensor Wire 270mm	1
992	Sonic 540 Rotor Spacers	1

**:: LRP Speed Controls**

LRP80230	Spin Super Brushless	1
LRP80250	Spin Pro Brushless	1
LRP80960	Flow Competition	1
LRP80970	Flow Works Team	1

**:: LRP Brushless Motors / Combos**

LRP50430	Vector K4 6.5 Turn	1
LRP50440	Vector K4 8.5 Turn	1
LRP50450	Vector K4 10.5 Turn	1
LRP50460	Vector K4 13.5 Turn	1
LRP50480	Vector K4 17.5 Turn	1
LRP50643	Vector X-20 10.5 Turn	1
LRP50644	Vector X-20 9.5 Turn	1
LRP50654	Vector X-20 8.5 Turn	1
LRP50664	Vector X-20 7.5 Turn	1
LRP50674	Vector X-20 6.5 Turn	1
LRP50684	Vector X-20 5.5 Turn	1
LRP50689	Vector X-20 5.0 Turn	1
LRP50694	Vector X-20 4.5 Turn	1
LRP50704	Vector X-20 4.0 Turn	1
LRP80741	Spin Super / K4 17.5 Turn	1
LRP80742	Spin Super / K4 13.5 Turn	1
LRP80743	Spin Super / K4 10.5 Turn	1

**:: LRP Chargers, Power Supply, Balancer**

LRP41281	Quadra Pro 2 Charger	1
LRP41555	Pulsar Touch Competition Charger	1
LRP42103	LiPo Balance Board XH	1
LRP42104	LiPo Balance Board FP/TP	1
LRP42105	LiPo Balance Board PQ	1
LRP42305	Pulsar Touch Temperature Sensor	1
LRP42306	Pulsar Touch Sensor Wire Splitter	1
LRP43200	LRP Competition 20A Power Supply	1
LRP45050	LRP 2in1 LiPo Guard + BEC	1
LRP45200	LiPo Parallel Balancer	1
LRP65800	High Power Solder Station	1
LRP65802	Soldering Tip 5mm	1
LRP65803	Soldering Tip 1.2mm	1
LRP65804	Soldering Handle	1
LRP81801	LRP Speedo Updater Spec 2	1

**:: LRP Misc.**

LRP50621	X-12 Optional Ceramic Ball Bearings	1
LRP50622	X-12 Small Parts Set	1
LRP50623	X-12 PreciSensor Unit	1
LRP50626	X-12 Alum Rear Cover	1
LRP50632	X-12 12.0mm Sintered Rotor	1
LRP50634	X-12 13.0mm Sintered Rotor	1
LRP50635	X-12 Stock Spec Rotor 12.45mm	1
LRP50636	Works Team X-12 12.0mm Rotor	1
LRP50637	Works Team X-12 12.5mm Rotor	1
LRP50638	Works Team X-12 13.0mm Rotor	1
LRP50639	X-12 Stock Spec 1S LiPo Rotor	1
LRP80135	BEC Stabilizing Capacitor	1
LRP82512	SXX Low Profile Fan	1
LRP82515	30mm Motor Fan/Clamp, Gunmetal	1
LRP82520	Radical Cooling Set, Blue	1
LRP82530	SXX Power Cap 3.7-4.8V	1
LRP82531	SXX Power Cap 6.0-7.4V	1
LRP819307	70mm High Flex Sensor Wire	1
LRP819310	100mm High Flex Sensor Wire	1
LRP819315	150mm High Flex Sensor Wire	1
LRP819320	200mm High Flex Sensor Wire	1

**:: 1/18 Kits and RTR's**

20103	RC18B2 - RC18T2 Team Kit	1
20110	RC18MT RTR (ready-to-run)	1
20115	RC18R Kamino RTR (ready-to-run)	1
20118	RC18R Niteline RTR (ready-to-run)	1
20121	SC18 RTR Brushless (ready-to-run)	1
20130	RC18LM RTR (ready-to-run)	1

**:: 1/12, 1/10 Kits and RTR's**

2042	Nitro TC3 RTR Plus (ready-to-run)	1
4020	FT 12R5.2 Kit	1
7023	RC10T4.1 FT Kit	1
7029	SC10 Associated/RC10.com Truck RTR (ready-to-run)	1
7030	SC10 KMC Wheels Race Truck RTR (ready-to-run)	1
7034	SC10 FT Kit	1
7037	RC10T4.1 RTR 2.4GHz Brushless (ready-to-run)	1
7046	SC10 RS RTR, Lucas Oil (ready-to-run)	1
7047	SC10 RS RTR, Monster Energy (ready-to-run)	1
7048	SC10 RS RTR, Pro Comp (ready-to-run)	1
7049	SC10 RS RTR, Rockstar/Makita (ready-to-run)	1
7050	SC10 RS RTR, Hart and Huntington (ready-to-run)	1
7092	GT2 RS Truck Nitro RTR (ready-to-run)	1
7093	SC10GT RTR (ready-to-run)	1
8020	FT RC10R5 Kit	1
8021	FT RC10R5-OVAL Kit	1
9039	RC10B4.1 RTR 2.4GHz Brushless (ready-to-run)	1
9062	FT B44.2 4WD Buggy Kit	1
30101	TC4 Club Racer 4WD Touring Car Race Roller	1
30107	FT TC6.1 4WD Touring Car Kit	1
30111	TC4 4WD Touring Car RTR (ready-to-run)	1
90004	SC10 4x4 Kit	1
90005	SC10 4x4 Lucas Oil RTR (ready-to-run)	1
90006	SC10 4x4 Pro Comp RTR (ready-to-run)	1
90007	SC10 4x4 Rockstar/Makita RTR (ready-to-run)	1
90010	SC10 4x4 FT Kit	1

**:: 1/8 Kits and RTR's**

20501	MGT 4.60 SE RTR (ready-to-run)	1
20502	MGT 8.0 Nitro RTR (ready-to-run)	1
20503	Limited Edition MGT 4.60 Nitro RTR, w/flag body (ready-to-run)	1
20504	Limited Edition MGT 8.0 Nitro RTR, w/flag body (ready-to-run)	1
80905	RC8RS "Race Spec" Nitro Buggy RTR (ready-to-run)	1
80906	RC8.2 Nitro Buggy FT Kit	1
80907	RC8.2e Electric Buggy FT Kit	1
80908	RC8.2e Electric Buggy RTR (ready-to-run)	1
80912	RC8T Championship Edition RC8T-RS "Race Spec" Nitro Truggy RTR (ready-to-run)	1
80933	SC8.2e Short Course Race Truck, Rockstar/Makita Electric RTR (ready-to-run)	1
80934	SC8.2e Short Course Race Truck, Slick Mist Electric RTR (ready-to-run)	1

**:: Lubes & Adhesives / Decals / Misc.**

1105	FT Green Slime Shock Lube	1
1596	FT Locking Adhesive	1
1597	FT Tire Adhesive, medium	1
6588	Black Grease - 4cc	1
6591	S.Diff Lube - 4cc	1
6636	Silicone Grease - 4cc	1
6727	Servo Tape	2
716	Reedy 2009 Sticker Set	1
717	Reedy Powered Logo Decal	1
3816	American Bumper Sticker	1
3820	AE Logo Decal Sheet	1
3834	AE Blue Embossed Logo Sticker	2
9782	B44.2 Decal Sheet	1



**:: Apparel**

SP35**	Reedy 09' White T-Shirt (M, L, XL, 2XL, 3XL)	1
SP36**	Reedy 09' Black T-Shirt (M, L, XL, 2XL, 3XL)	1
SP37**	Reedy 2012 T-shirt - Black (S, M, L, XL, 2XL, 3XL)	1
SP38**	Reedy Trucker Hat	1
SP39**	Reedy Patch	1
SP66**	AE Stencil Blue T-Shirt (S, M, L, XL, 2-6XL)	1
SP67**	AE Stencil Gray Sweatshirt (S, M, L, XL, 2XL, 3XL)	1
SP69**	AE 26 Time World Championship T-Shirt, Black (S, M, L, XL, 2XL, 3XL)	1
SP70**	Associated Windbreaker (S, M, L, XL, 2XL, 3XL)	1
SP71**	Associated Winter Jacket (S, M, L, XL, 2XL)	1
SP73**	AE Long Sleeve T-Shirt (S, M, L, XL, 2XL)	1
SP74**	AE White T-Shirt (S, M, L, XL, 2XL, 3XL, 4XL)	1
SP75**	AE Blue T-Shirt (S, M, L, XL, 2-6XL)	1
SP76**	AE Black T-Shirt (S, M, L, XL, 2XL, 3XL, 4XL)	1
SP77**	AE 2012 T-Shirt, Blue (S, M, L, XL, 2XL, 3XL)	1
SP78**	AE 2012 T-Shirt, White (S, M, L, XL, 2XL, 3XL)	1
SP79**	AE 2012 T-Shirt, Black (S, M, L, XL, 2XL, 3XL)	1
SP411S	AE Hat 11' Flat Bill Black S/M	1
SP411L	AE Hat 11' Flat Bill Black L/XL	1
SP413S	26 Time World Championship Hat S/M	1
SP413L	26 Time World Championship Hat L/XL	1
SP417	1/10 FT Motor Bag	1
SP418	Factory Team 1/10 Car Carrier Bag	1
SP420**	AE Pit Gloves (M, L, XL)	Pr.
SP421S	AE 2012 Hat, Black, Flat Bill, S/M	1
SP421L	AE 2012 Hat, Black, Flat Bill, L/XL	1
SP422S	AE 2012 Hat, Black, Curved Bill, S/M	1
SP422L	AE 2012 Hat, Black, Curved Bill, L/XL	1
SP423S	AE 2012 Hat, White, Flat Bill, S/M	1
SP423L	AE 2012 Hat, White, Flat Bill, L/XL	1
SP424S	AE 2012 Hat, White, Curved Bill, S/M	1
SP424L	AE 2012 Hat, White, Curved Bill, L/XL	1
715	Reedy 2009 Track Banner	1
110684	Team Associated Track Banner	1

\*\* Use part number plus the desired size when ordering!

**:: Contact Information**

**Associated Electrics, Inc.**  
**26021 Commercentre Drive**  
**Lake Forest, CA 92630-8853 USA**  
<http://www.TeamAssociated.com>  
<http://www.RC10.com>  
<http://twitter/Team Associated>  
<http://bit.ly/AEonFacebook>

**call: (949) 544-7500**  
**fax: (949) 544-7501**

**Check out the following web sites for all of our electric kits, current products, new releases, setup help, tips, and racing info!**

**[www.TeamAssociated.com](http://www.TeamAssociated.com) - [www.RC10.com](http://www.RC10.com)**

**:: Tools**

1111	FT Turnbuckle Wrench	1
1450	FT Ride Height Gauge	1
1541	FT Hex Driver Set, (7 pcs)	1
1542	FT .050" Silver Hex Driver	1
1543	FT 1/16" Black Hex Driver	1
1544	FT 1.5mm Purple Hex Driver	1
1545	FT 5/64" Blue Hex Driver	1
1546	FT 3/32" Gold Hex Driver	1
1547	FT 2.5mm Green Hex Driver	1
1548	FT 3mm Red Hex Driver	1
1551	FT Screwdriver Set	1
1553	FT Phillips Silver Screwdriver	1
1554	FT Silver Spring Hook Tool	1
1561	FT Nut Driver Set, (6 pcs)	1
1562	FT 3/16" Black Nut Driver	1
1563	FT 1/4" Red Nut Driver	1
1564	FT 5.5mm Red Nut Driver	1
1565	FT 11/32" Green Nut Driver	1
1566	FT 7.0mm Silver Nut Driver	1
1567	FT 8mm Gold Nut Driver	1
1589	FT 5/64" Blue Ball Hex Driver	1
1590	FT 3/32" Gold Ball Hex Driver	1
1592	FT Ball Hex Driver Set, (3 pcs)	1
1655	FT 8-Piece 1/4" Hex Drive Set	1
1656	FT 1/4" Hex Drive Handle, without tips	1
1657	FT 1/4" Hex Drive .050" Tip	1
1658	FT 1/4" Hex Drive 1/16" Tip	1
1659	FT 1/4" Hex Drive 5/64" - 2.0mm Tip	1
1660	FT 1/4" Hex Drive 3/32" Tip	1
1661	FT 1/4" Hex Drive 1.5mm Tip	1
1662	FT 1/4" Hex Drive 2.5mm Tip	1
1663	FT 1/4" Hex Drive 3/16" Nut Driver Tip	1
1664	FT 1/4" Hex Drive 1/4" Nut Driver Tip	1
1665	FT 1/4" Hex Drive 11/32" Nut Driver Tip	1
1666	FT 1/4" Hex Drive 5.5mm Nut Driver Tip	1
1667	FT 1/4" Hex Drive 7.0mm Nut Driver Tip	1
1668	FT 1/4" Hex Drive 8.0mm Nut Driver Tip	1
1669	FT 1/4" Hex Drive 5/64" - 2.0mm Ball End Tip	1
1670	FT 1/4" Hex Drive 3/32" Ball End Tip	1
1671	FT 1/4" Hex Drive Standard Screwdriver Tip	1
1672	FT 1/4" Hex Drive Phillips Screwdriver Tip	1
1673	FT 1/4" Hex Drive 2.5mm Ball End Tip	1
1674	FT 1/4" 5 Piece Power Tool Tips Set (5/64-2.0mm, 1.5mm, 2.5mm, 5/64"- 2.0mm ball, 2.5mm ball)	1
1719	FT Camber + Track Width Tool	1
1737	FT Body Scissors	1
3718	12 Inch Nylon Wire Ties	12
3719	6 Inch Nylon Wire Ties	12
3720	8 Inch Nylon Wire Ties	12
3987	FT Droop Gauge	1
6429	Shock Building Tool	1
6956	Molded Tools, Set	1
7709	4 Inch Nylon Wire Ties	12

**:: Notes**

A large, empty rectangular area intended for taking notes, framed by a thin black border.

### Front Suspension

**Anti Roll Bar:**

- 0.047" Black
- 0.055" Silver
- None

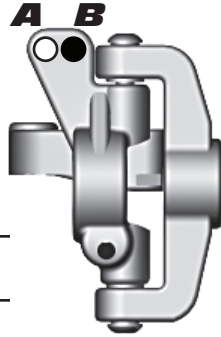

Bumpsteer Washer: 0

Camber: -1°

Toe: 0°

Ride Height: 21mm

Washers: 1

**Steering Rack:**

Back:   
Front:



Notes: Measure ride height behind front bumper

### Rear Suspension

**Anti Roll Bar:**

- 0.047" Black
- 0.055" Silver
- None

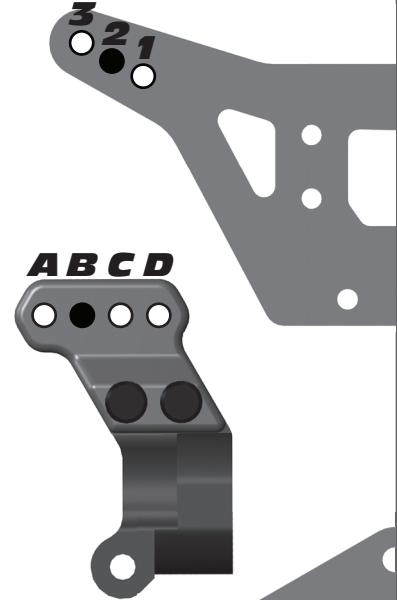

Camber: -1°

Toe: 3°

Ride Height: 20mm

Anti-Squat: 0.030

Aluminum Hub Tower:  
A   
B   
C

Wheelbase: Washers: 1  
Long   
Medium   
Short

Notes: Measure ride height on back corner of chassis

### Front Shocks

Spring: Blue (3.60lb) Piston: 1.6  
Shock Oil: 35 wt Limiter: 1

### Rear Shocks

Spring: White (2.10lb) Piston: 1.7  
Shock Oil: 35 wt Limiter: 1

### Electronics / Weight

Motor & Wind: \_\_\_\_\_  
Pinion: \_\_\_\_\_ Spur Gear: \_\_\_\_\_  
Batteries: \_\_\_\_\_  
Battery Placement: Front  Back   
Ballast Weight: \_\_\_\_\_  
Chassis Weight: \_\_\_\_\_

Radio: \_\_\_\_\_  
Throttle / Brake e.p.a: \_\_\_\_\_  
Throttle / Brake expo: \_\_\_\_\_  
Servo: \_\_\_\_\_ Steering Expo: \_\_\_\_\_  
ESC: \_\_\_\_\_  
ESC Settings: \_\_\_\_\_

### Front Tires

Tire: \_\_\_\_\_  
Compound: \_\_\_\_\_  
Insert: \_\_\_\_\_  
Wheel: #9767 AE 4WD Front Wheel

### Rear Tires

Tire: \_\_\_\_\_  
Compound: \_\_\_\_\_  
Insert: \_\_\_\_\_  
Wheel: #9695 AE Rear Hex Wheel

### Drivetrain

Slipper: \_\_\_\_\_  
2 Pads  3 Pads  4 Pads   
Notes: \_\_\_\_\_

### Differentials

Front: \_\_\_\_\_  
Rear: \_\_\_\_\_  
Notes: \_\_\_\_\_

### Other

Body Type: JConcepts B44.2 Finisher  
Wing Type: 6.5" high Wing Angle: 9°

### Race and Vehicle Comments







Qualify: \_\_\_\_\_ Main: \_\_\_\_\_ Finish: \_\_\_\_\_ TQ: \_\_\_\_\_  
Comments: \_\_\_\_\_

### Track Info





Smooth:  Bumpy:  Blue Groove:   
Traction:  High:  Medium:  Low:   
Soft Dirt:  Grass:  Clay:  Wet:   
Dusty:  Other: \_\_\_\_\_

**:: Hardware - 1:1 Scale View**







**Cap Head (shcs)**

-  **4-40x5/16 (6932)**  
*(aluminum ,4145)*
-  **4-40x3/8 (6924)**  
*(aluminum ,6860)*
-  **4-40x7/16 (7874)**  
*(aluminum, 7873)*
-  **4-40x1/2 (6925)**
-  **4-40x7/8 (7738)**
-  **3x6mm (6515)**  
*(motor mounting screws)*





**Flat Head (fhcs)**

-  **4-40x5/16 (7673)**
-  **4-40x3/8 (6292)**
-  **4-40x7/16 (9765)**
-  **4-40x5/8 (6915)**

**Button Head (bhcs)**

-  **2-56x1/8 (9645)**
-  **2-56x5/16 (4334)**
-  **4-40x1/4 (6288)**
-  **4-40x3/8 (6917)**
-  **4-40x7/16 (2221)**
-  **4-40x3/4 (7413)**





**Ball Bearings**

-  **Steering Bearing (9746)**
-  **3/16x5/16 (6906)**
-  **3/16x3/8 (3977)**
-  **3/16x1/2 RS (7935)**
-  **3/8x5/8" RS (3976)**

**Shims and Washers**

-  **.030 Ballstud Washer (9630)**
-  **.030 Nylon Spacer (4187)**
-  **Servo Mount Washer (7337)**
-  **#4 Washer (6936)**
-  **Input Shaft Shim - Black (3911)**
-  **3/16 Axle Shim - Silver (7368)**
-  **Outdrive Shim (3911)**

**Nuts (lock/plain)**

-  **4-40 Aluminum Locknut (4449)**
-  **4-40 Plastic Nut (6472)**
-  **5-40 Nylon Locknut (6222)**
-  **8-32 LP Steel Locknut (6953)**
-  **8-32 Steel Locknut (6952)**

**Top Hat Bushings**

-  **Small Top Hat Bushing (3874)**
-  **Large Top Hat Bushing (9647)**

**Ballstuds**

-  **Silver .20 Short (6276)**
-  **Silver .30 Long (6277)**
-  **Black .30 Short (3983)**

**Clips**

-  **E-clip 1/8 (6299)**

**Diff Balls**

-  **5/64 Diff Thrust Balls (6574)**
-  **3/32 Carbide Diff Balls (6581)**

**Notes:**

### Front Suspension

#### Anti Roll Bar:

- 0.047" Black   
 0.055" Silver   
 None



Bumpsteer  
 Washer: \_\_\_\_\_

Camber: \_\_\_\_\_

Toe: \_\_\_\_\_

Ride Height: \_\_\_\_\_

Washers: \_\_\_\_\_

#### Steering Rack:

Back:   
 Front:

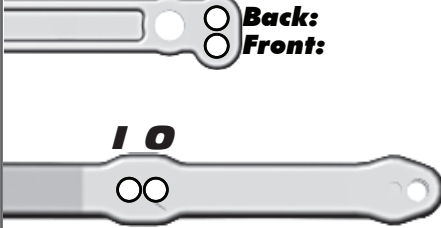

Notes: \_\_\_\_\_  
 \_\_\_\_\_  
 \_\_\_\_\_

### Rear Suspension

#### Anti Roll Bar:

- 0.047" Black   
 0.055" Silver   
 None

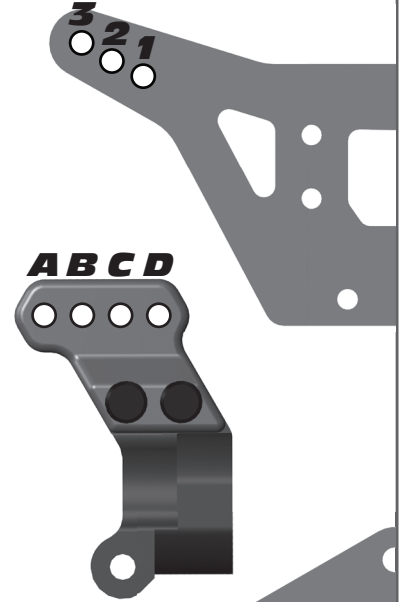

Camber: \_\_\_\_\_

Toe: \_\_\_\_\_

Ride Height: \_\_\_\_\_

Anti-Squat: \_\_\_\_\_

#### Aluminum Hub Tower:

- A   
 B   
 C

#### Wheelbase:

- Long   
 Medium   
 Short

Washers: \_\_\_\_\_



Notes: \_\_\_\_\_  
 \_\_\_\_\_  
 \_\_\_\_\_

### Front Shocks

Spring: \_\_\_\_\_ Piston: \_\_\_\_\_  
 Shock Oil: \_\_\_\_\_ Limiter: \_\_\_\_\_

### Rear Shocks

Spring: \_\_\_\_\_ Piston: \_\_\_\_\_  
 Shock Oil: \_\_\_\_\_ Limiter: \_\_\_\_\_

### Electronics / Weight

Motor & Wind: \_\_\_\_\_  
 Pinion: \_\_\_\_\_ Spur Gear: \_\_\_\_\_  
 Batteries: \_\_\_\_\_  
 Battery Placement: Front  Back   
 Ballast Weight: \_\_\_\_\_  
 Chassis Weight: \_\_\_\_\_

Radio: \_\_\_\_\_  
 Throttle / Brake e.p.a: \_\_\_\_\_  
 Throttle / Brake expo: \_\_\_\_\_  
 Servo: \_\_\_\_\_ Steering Expo: \_\_\_\_\_  
 ESC: \_\_\_\_\_  
 ESC Settings: \_\_\_\_\_

### Front Tires

Tire: \_\_\_\_\_  
 Compound: \_\_\_\_\_  
 Insert: \_\_\_\_\_  
 Wheel: \_\_\_\_\_

### Rear Tires

Tire: \_\_\_\_\_  
 Compound: \_\_\_\_\_  
 Insert: \_\_\_\_\_  
 Wheel: \_\_\_\_\_

### Drivetrain

Slipper: \_\_\_\_\_  
 2 Pads  3 Pads  4 Pads   
 Notes: \_\_\_\_\_

### Differentials

Front: \_\_\_\_\_  
 Rear: \_\_\_\_\_  
 Notes: \_\_\_\_\_

### Other

Body Type: \_\_\_\_\_  
 Wing Type: \_\_\_\_\_ Wing Angle: \_\_\_\_\_

### Race and Vehicle Comments

Qualify: \_\_\_\_\_ Main: \_\_\_\_\_ Finish: \_\_\_\_\_ TQ: \_\_\_\_\_  
 Comments: \_\_\_\_\_  
 \_\_\_\_\_

### Track Info

Smooth:  Bumpy:  Blue Groove:   
 Traction:  High:  Medium:  Low:   
 Soft Dirt:  Grass:  Clay:  Wet:   
 Dusty:  Other: \_\_\_\_\_



**Associated Electrics, Inc.  
26021 Commercentre Dr.  
Lake Forest, CA 92630 USA**

**<http://www.TeamAssociated.com>**

**<https://www.RC10.com>**

**[https://twitter/Team\\_Associated](https://twitter/Team_Associated)**

**<https://bit.ly/AEonFacebook>**

**call: (949) 544-7500 - fax: (949) 544-7501**

**Check out the following web sites for all of our kits,  
current products, new releases, setup help, tips, and racing info!  
[www.TeamAssociated.com](http://www.TeamAssociated.com) - [www.RC10.com](http://www.RC10.com)**